

# MC4

## Submersible pumps

 Sewage water

 Civil use

 Industrial use



### PERFORMANCE RANGE

- Flow rate up to **2600 l/min** (156 m<sup>3</sup>/h)
- Head up to **16 m**

### APPLICATION LIMITS

- **10 m** maximum immersion depth (with a sufficiently long power cable)
- Maximum liquid temperature **+40 °C**
- Passage of suspended solids up to **Ø 55 mm**
- Minimum immersion depth for continuous service: **550 mm**

### CONSTRUCTION AND SAFETY STANDARDS

- **10 m** long power cable

EN 60335-1  
IEC 60335-1  
CEI 61-150

EN 60034-1  
IEC 60034-1  
CEI 2-3



### CERTIFICATIONS

Company with management system certified DNV  
ISO 9001: QUALITY



### INSTALLATION AND USE

**MC4** series pumps, made from heavy gauge robust cast iron, resistant to abrasion and long-lasting, are fitted with a DOUBLE-CHANNEL impeller and are capable of pumping liquids containing short fibred suspended solids. They are ideal for pumping **sewage, waste water, water mixed with mud, groundwater and surface water** in locations such as blocks of flats, public buildings, factories, multi-storey and underground car parks, washing areas, etc.

### PATENTS - TRADE MARKS - MODELS

- Patent Pending

### OPTIONS AVAILABLE ON REQUEST

- Pumps equipped with internal probes detecting the presence of water in the oil chamber
- Pumps with double cable for star/delta start
- Other voltages or 60 Hz frequency

### CHARACTERISTIC CURVES AND PERFORMANCE DATA

50 Hz n= 1450 min<sup>-1</sup>

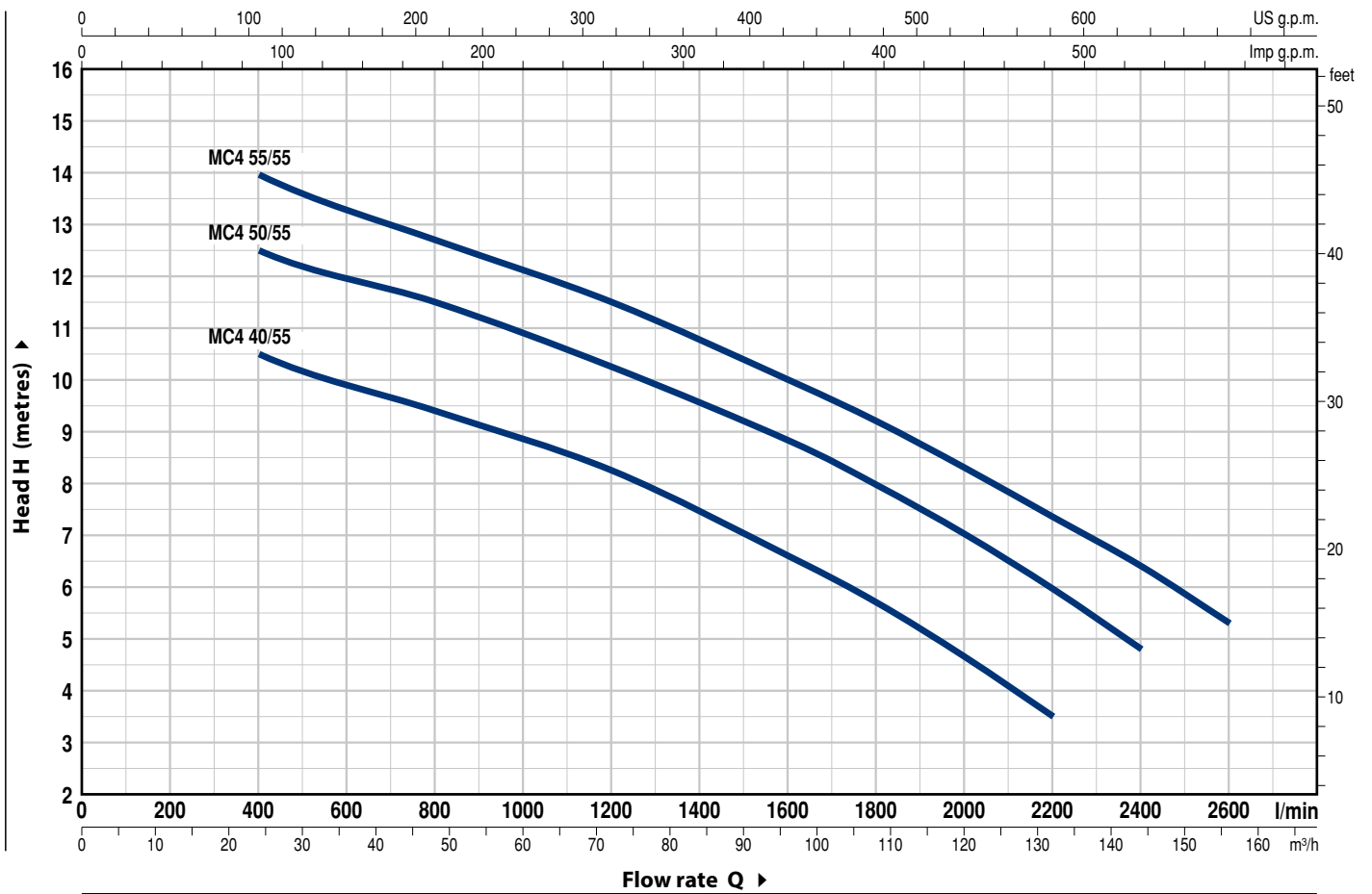

MODEL Three-phase	POWER (P <sub>2</sub> )		Q	0	24	48	72	96	108	120	132	144	156
	kW	HP		0	400	800	1200	1600	1800	2000	2200	2400	2600
MC4 40/55	3	4	H metres	12.5	10.5	9.4	8.3	6.6	5.7	4.7	3.5		
MC4 50/55	3.7	5		14.5	12.5	11.5	10.3	8.8	8	7	6	4.8	
MC4 55/55	4	5.5		16	13.9	12.7	11.5	10	9.2	8.3	7.4	6.4	5.3

Q = Flow rate H = Total manometric head

Tolerance of characteristic curves in compliance with EN ISO 9906 Grade 3B.

## POS. COMPONENT CONSTRUCTION CHARACTERISTICS

<b>1 PUMP BODY</b>	Cast iron with an Epoxy Electro Coating treatment, with threaded port in compliance with ISO 228/1
<b>2 BASE</b>	Cast iron with an Epoxy Electro Coating treatment
<b>3 IMPELLER</b>	DOUBLE-CHANNEL type in cast iron with an Epoxy Electro Coating treatment
<b>4 MOTOR CASING</b>	Cast iron with an Epoxy Electro Coating treatment
<b>5 CASING</b>	Cast iron with an Epoxy Electro Coating treatment
<b>6 MOTOR SHAFT</b>	Stainless steel AISI 431

### 7 TWO MECHANICAL SEALS SEPARATED BY AN OIL CHAMBER

Seal Model	Shaft Diameter	Position	Materials		
			Stationary ring	Rotational ring	Elastomer
MG91-40D	Ø 40 mm	Motor side	Silicon carbide	Graphite	NBR
		Pump side	Silicon carbide	Silicon carbide	NBR

### 8 BEARINGS 6309 ZZ C3 ENS / 6306 ZZ C3 ENS

### 9 ELECTRIC MOTOR

- three-phase 400 V - 50 Hz  
with thermal overload protector incorporated into the winding
- Insulation: class F
- Protection: IP X8

### 9 POWER CABLE

"H07 RN-F" type  
**Standard length 10 metres**

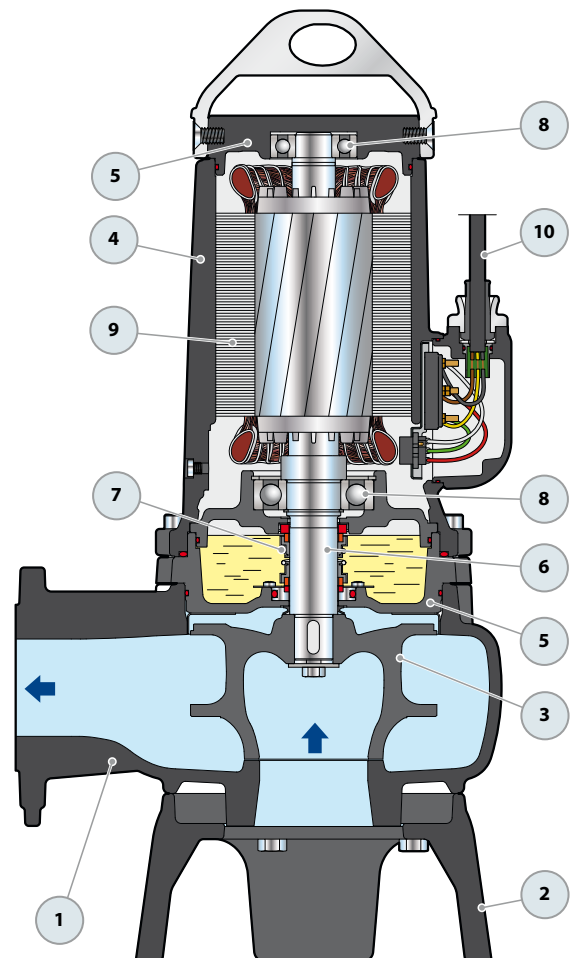

## DIMENSIONS AND WEIGHT

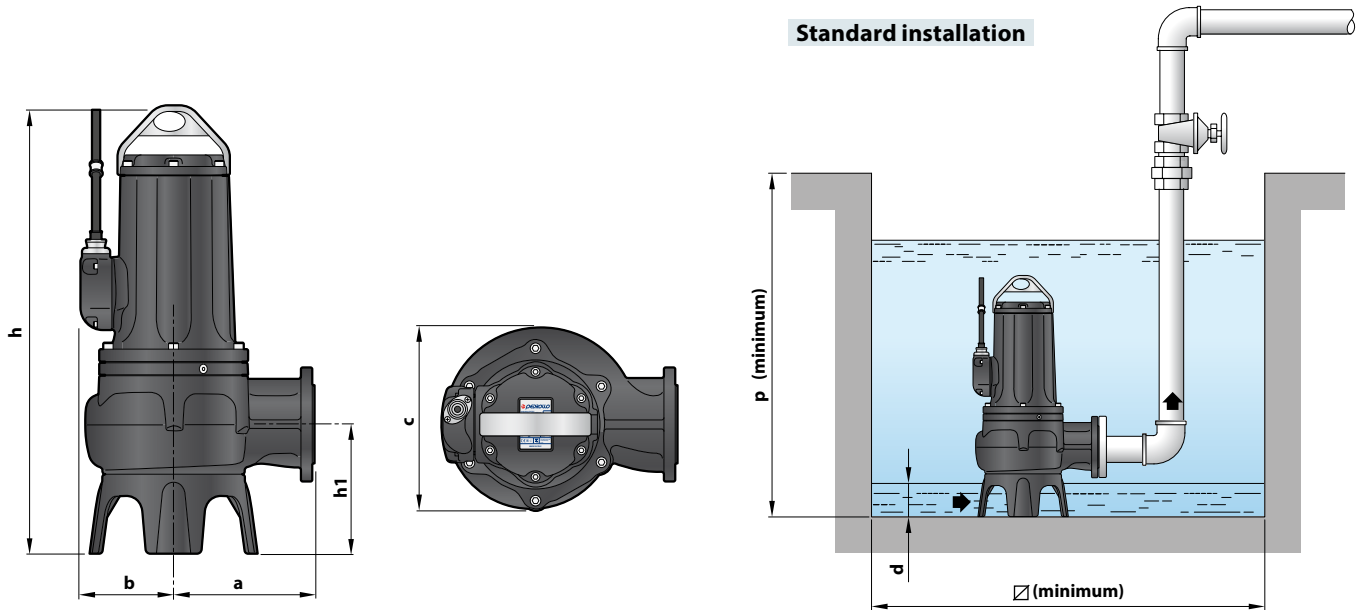

MODEL	Passage of solids	DIMENSIONS mm								kg
		a	b	c	h	h1	d	p	∅	
Three-phase										3~
MC4 40/55	Ø 55 mm	248	165	320	792	228	140	1000	1000	114
MC4 50/55										119
MC4 55/55										122

## FLANGED PORT

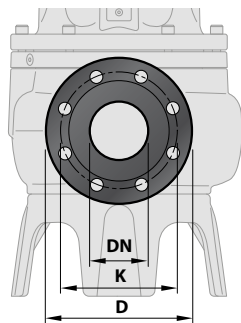

MODEL	FLANGE DN	K mm	D mm	HOLES	
				N.	∅ (mm)
Three-phase	80 (PN10)	160	200	8	18
MC4 40/55					
MC4 50/55					
MC4 55/55					

## COUNTERFLANGE

(INCLUDED IN THE CONNECTION SUPPORT KIT)

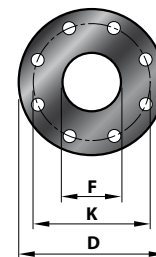

MODEL	FLANGE DN	F	K mm	D mm	HOLES	
					N.	∅ (mm)
Three-phase	80	3"	160	200	8	18
MC4 40/55						
MC4 50/55						
MC4 55/55						

## ABSORPTION

MODEL	VOLTAGE
Three-phase	400 V
MC4 40/55	5.5 A
MC4 50/55	7.7 A
MC4 55/55	8.3 A

## PALLETIZATION

MODEL	GROUPAGE
Three-phase	n. pumps
MC4 40/55	4
MC4 50/55	4
MC4 55/55	4

# BASE PEDESTAL KIT VXC4 – MC4

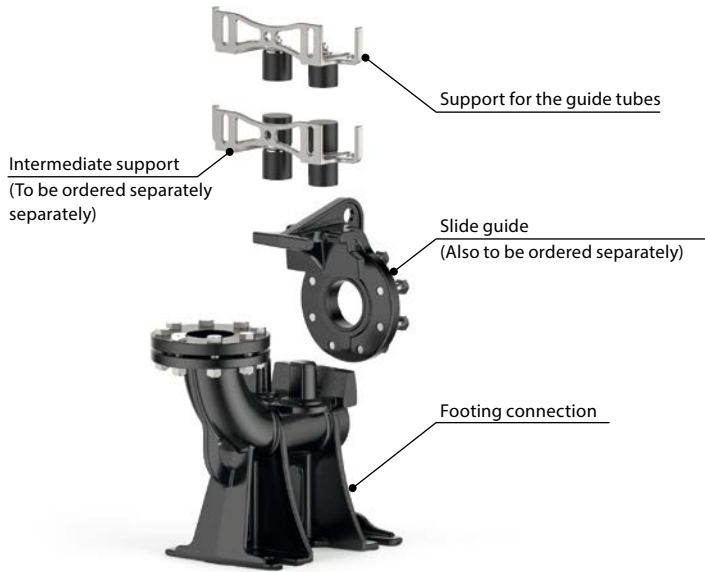

## VERTICAL DELIVERY VERSION WITH 2" GUIDE TUBES

For <b>VXC4</b>	Cod. ASSPVXC4V	DN 4"
For <b>MC4</b>	Cod. ASSPMC4V	DN 3"

Kit consisting of:

- footing connection complete with counterflange
- slide guide with screws and seals
- support for the guide tubes

## STANDARD INSTALLATION

1. Pump
2. Footing connection
3. Guide tubes
4. Support for the guide tubes
5. Intermediate support for the guide tubes
6. Lifting chain
7. Control box
8. Stop float switch
9. Starting float switch
10. Starting float switch auxiliary pump
11. Alarm float switch
12. Non-return valve

## SLIDE GUIDE (Also to be ordered separately)

For <b>VXC4</b>	Cod. ASSFL100
For <b>MC4</b>	Cod. ASSFL080

Complete with screws and seals

## GUIDE TUBES (AISI 304 stainless steel)

Cod. 54SARTG006	Ø 2"
-----------------	------

**In order to ensure stability, insert the intermediate support every three metres of guide tube (recommended)**

Maximum length of the tube plank: 6 metres

## INTERMEDIATE SUPPORT (Can be ordered separately)

Cod. 859SV349INTFA	For guide tubes Ø 2"
--------------------	----------------------

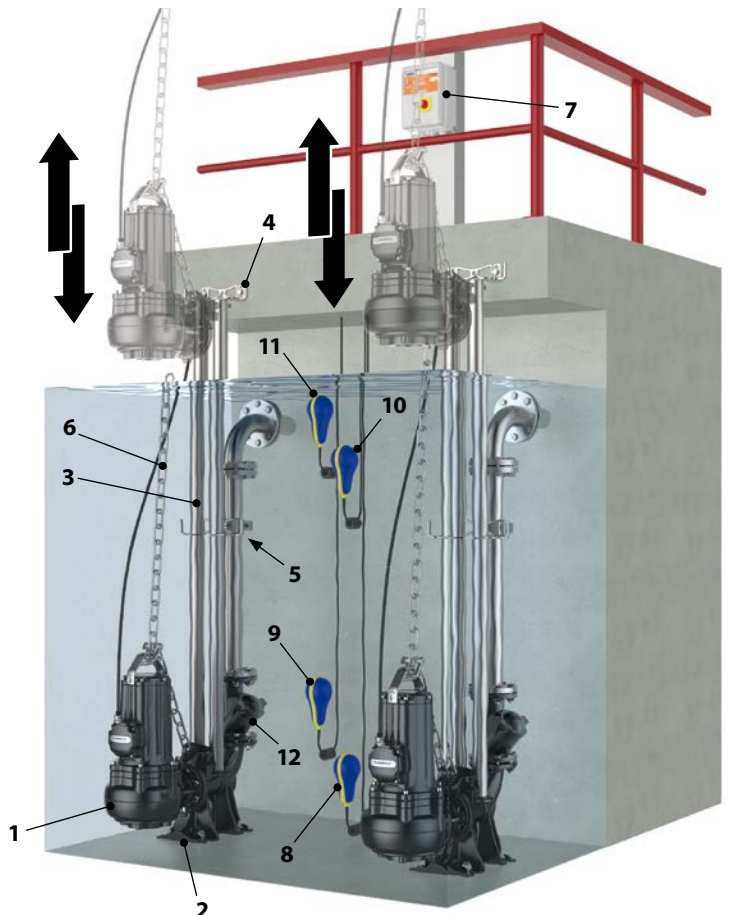

## DIMENSIONS

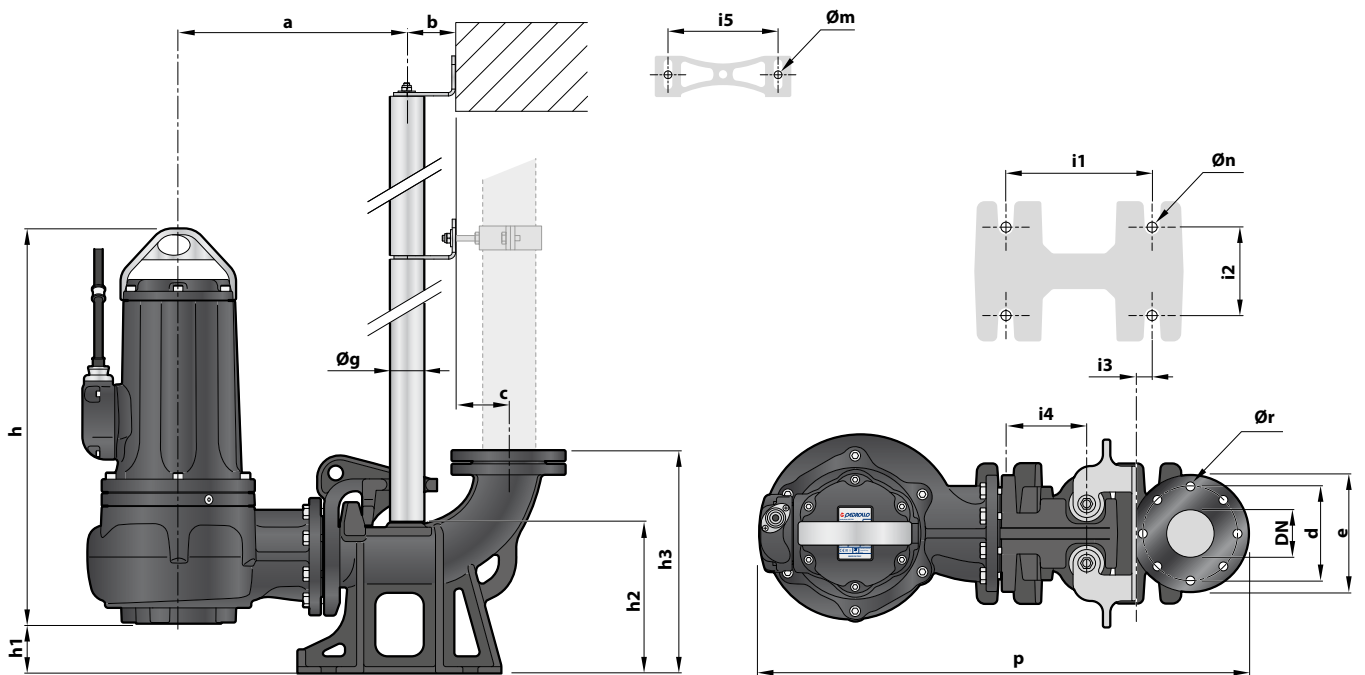

MODEL	Passage of solids mm	PORT DN	DIMENSIONS mm																		
			a	b	c	d	e	p	h	h1	h2	h3	i1	i2	i3	i4	i5	Øg	Øm	Øn	Ør
Three-phase																					
VXC4 40/100	Ø 100	4"																			
VXC4 50/100			376	85	105	180	220	841	695	107	266	426	250	150	34	130	186	2"	13	16	18
VXC4 55/100																					

MODEL	Passage of solids mm	PORT DN	DIMENSIONS mm																		
			a	b	c	d	e	p	h	h1	h2	h3	i1	i2	i3	i4	i5	Øg	Øm	Øn	Ør
Three-phase																					
MC4 40/55	Ø 55	3"																			
MC4 50/55			396	85	95	160	200	841	680	92	256	592	250	150	34	130	186	2"	13	16	18
MC4 55/55																					