



SPARE PARTS LIST

FLOOR SAWS

FS7000 DL, 2017-02

AF FS7000DL
5th WHEEL ASSEMBLY

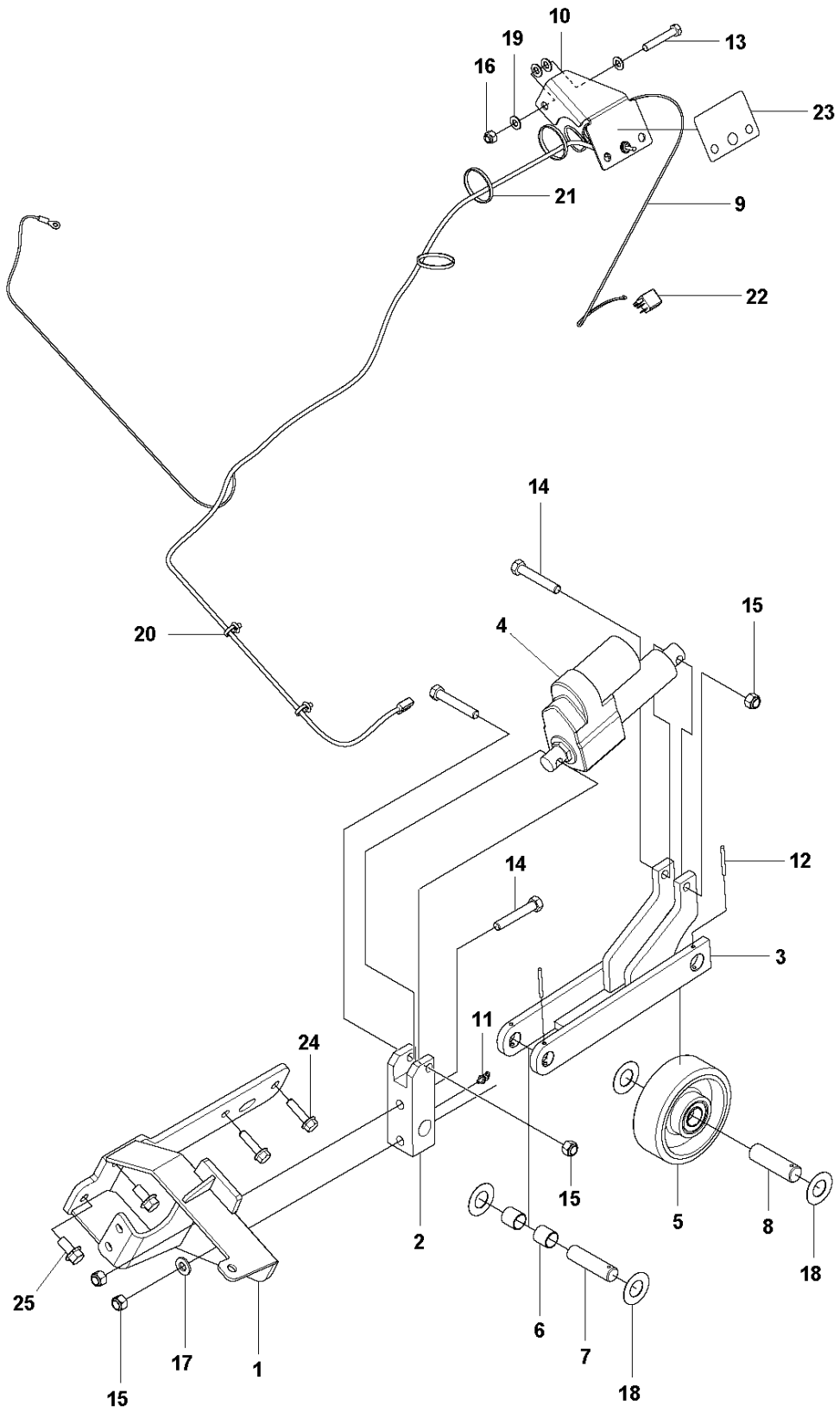

Ref	Part No	Description	Remark	QTY KIT
1	501 70 37-01	BRACKET		1
2	574 85 90-03	PIVOT		1
3	574 85 33-01	LIFTING ARM		1
4	502 28 76-02	CYLINDER		1
5	590 64 98-01	WHEEL		1
6	575 63 11-01	BEARING BUSH		2
7	574 85 33-04	LIFTING ARM		1
8	574 85 33-05	LIFTING ARM		1
9	501 15 16-01	WIRING HARNESS		1
10	581 98 93-01	BRACKET		1
11	542 16 42-97	GREASE		1
12	541 20 51-33	PEN		2
13	725 25 01-76	SCREW EHHM		1
14	542 02 14-04	FS900T SCREW/		4
15	539 10 13-31	NUT		4
16	732 25 20-01	HEXAGON LOCKING NUT		1
17	539 99 02-50	WASHER		1
18	542 04 64-02	WASHER		4
19	734 11 72-01	WASHER		4
20	583 95 95-01	CLAMP		2
21	542 19 71-01	CABLE		4
22	581 07 45-01	RELAY		1
23	582 52 10-01	DECAL		1
24	585 97 53-01	SCREW EHHFM		2
25	585 23 59-01	SCREW EHHFM		2

A FS7000DL
BASEPLATE

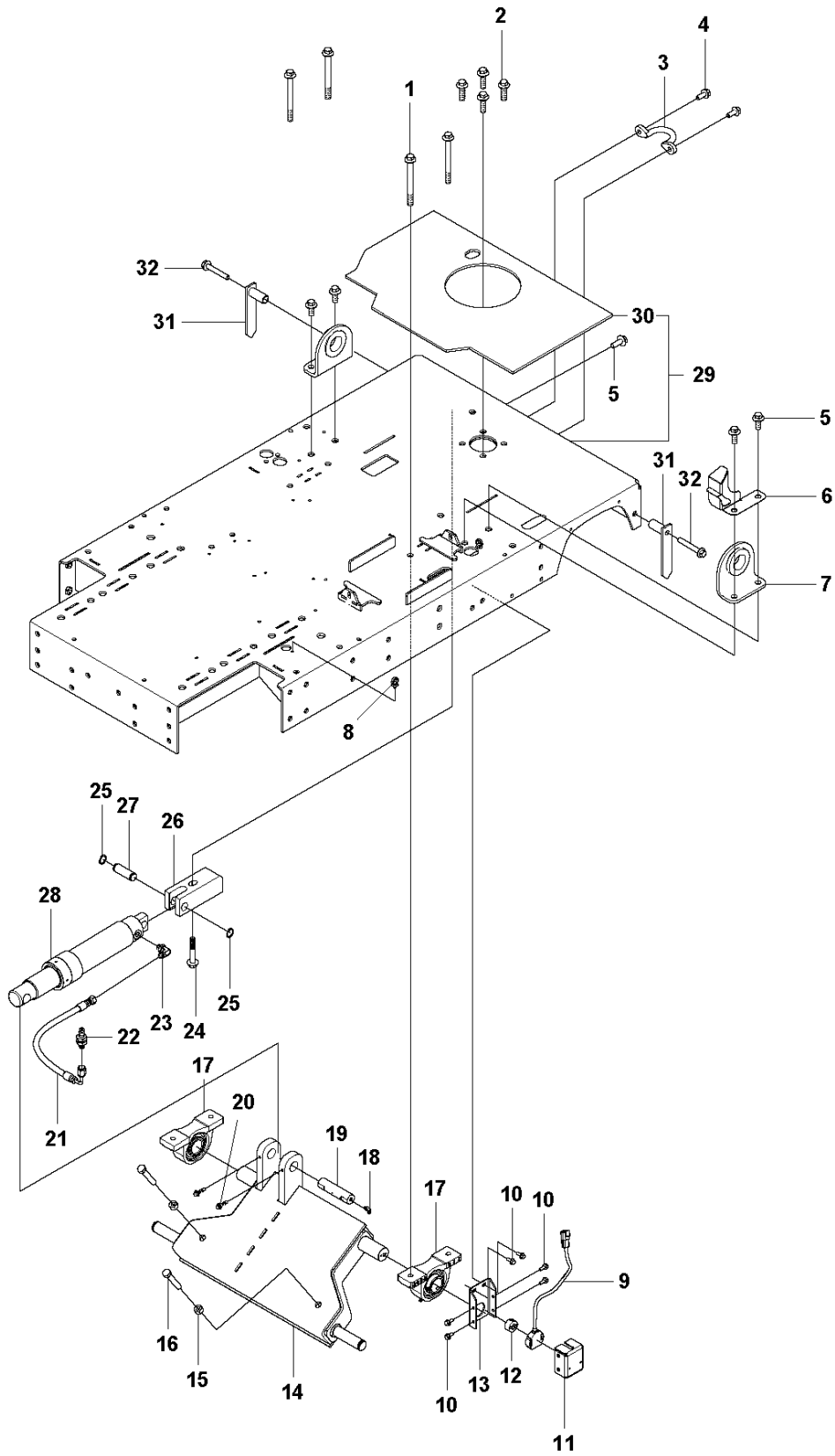

BASE PLATE

FS7000 DL, 2017-02

Ref	Part No	Description	Remark	QTY KIT
1	576 65 48-13	SCREW EHHFM		4
2	576 65 48-04	SCREW EHHFM		4
3	504 58 03-02	LOOP		1
4	585 97 31-01	SCREW EHHFM		2
5	576 65 48-03	SCREW EHHFM		5
6	588 56 85-01	BRACKET		1
7	579 23 22-01	MOUNT		2
8	583 95 95-01	CLAMP		3
9	581 14 07-01	SENSOR		1
10	585 98 06-01	SCREW EHHFM		6
11	579 33 02-01	BOX		1
12	581 14 06-01	MAGNET		1
13	579 33 03-01	PLATE		1
14	589 38 63-01	BRACKET	60"	1
14	587 71 55-01	FRONT AXLE	36",42",48"	1
15	731 23 22-01	HEXAGON NUT		2
16	725 25 46-71	SCREW EHHM		2
17	579 73 54-01	BALL BEARING		2
18	581 06 88-01	GREASE		1
19	590 22 42-01	SHAFT		1
20	542 19 90-53	SCREW		2
21	590 62 81-01	HYDRAULIC HOSE		1
22	581 20 55-01	ADAPTER		1
23	590 62 80-01	ADAPTER		1
24	576 65 48-07	SCREW EHHFM		1
25	735 31 22-01	CIRCLIP		2
26	579 59 56-01	BLOCK		1
27	579 52 58-01	SHAFT		1
28	501 49 32-01	HYDRAULIC CYLINDER		1
29	590 19 81-01	BASEPLATE		1
30	581 16 72-01	INSULATOR	Insulator included	1
31	581 11 52-01	POINTER		2
32	581 24 33-01	SCREW EHHFM		2

C FS7000DL
BASEPLATE 36" - 42"

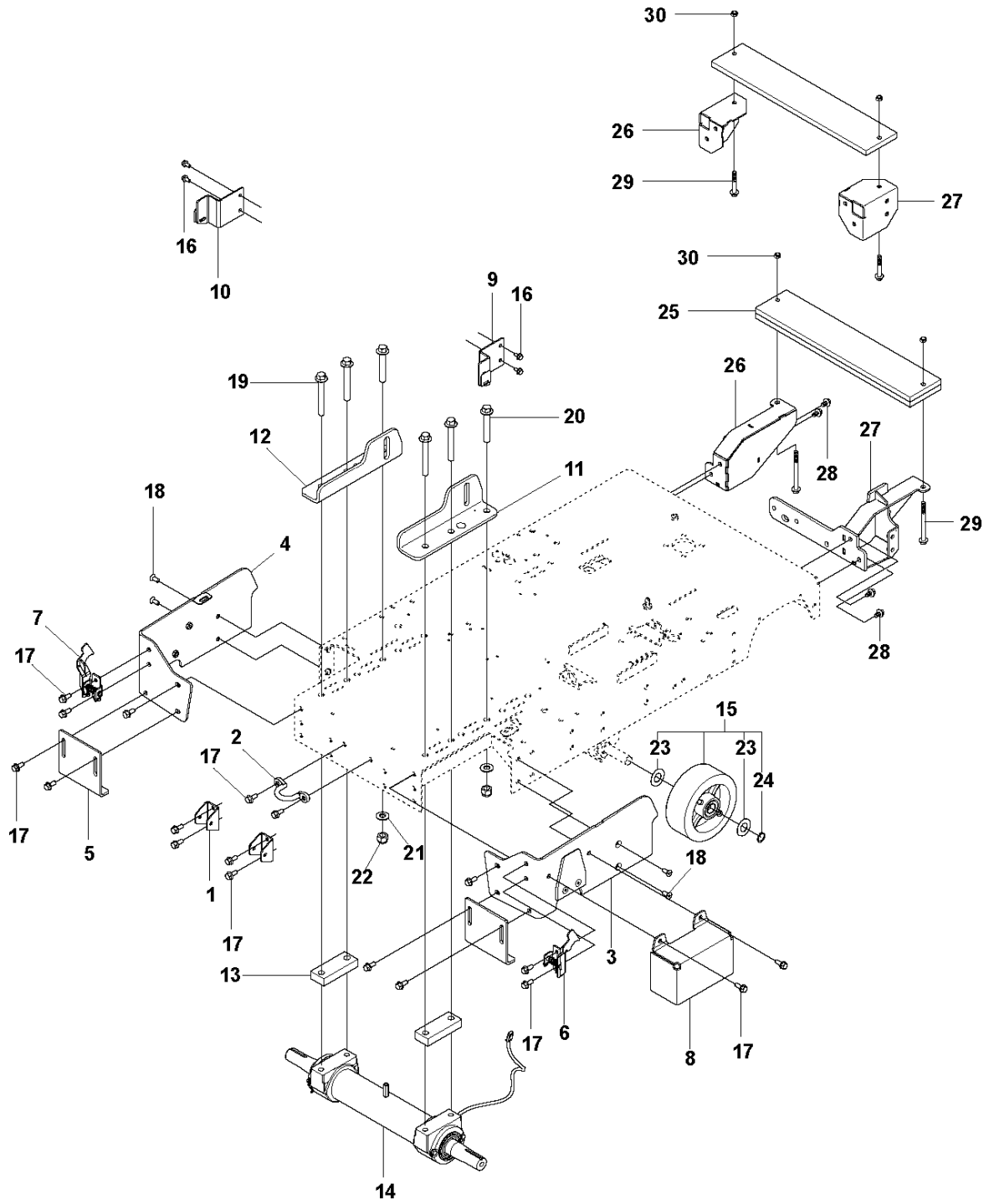

Ref	Part No	Description	Remark	QTY	KIT
1	579 35 94-01	BRACKET		2	
2	504 58 03-02	LOOP		1	
3	582 41 20-01	BRACKET		1	
4	582 41 21-01	BRACKET		1	
5	588 83 21-01	GUARD		2	
6	581 10 72-01	LOCK		1	
7	581 10 71-01	LOCK		1	
8	579 36 11-01	BRACKET		1	
9	586 16 79-01	BRACKET		1	
10	586 16 80-01	BRACKET		1	
11	501 87 14-01	ENGINE		1	
12	501 87 15-01	ENGINE		1	
13	582 20 47-01	BLOCK		2	
14	590 19 83-01	BLADE SHAFT		1	
15	590 19 84-01	WHEEL		1	
16	585 97 56-01	SCREW EHHFM		4	
17	585 97 31-01	SCREW EHHFM		18	
18	725 64 93-01	SCREW IHCSFM		4	
19	581 24 94-05	SCREW EHHFM		4	
20	581 24 94-02	SCREW EHHFM		2	
21	539 97 69-82	WASHER		2	
22	576 87 89-28	NUT		2	
23	542 04 64-02	WASHER		4	15
24	735 31 26-01	CIRCLIP		2	15
25	579 36 00-02	WEIGHT	36" and 42"	1	
25	579 36 00-02	WEIGHT	42" 3-speed w/o 5th Wheel"	2	
26	501 70 44-01	BRACKET	w/ 5th Wheel	1	
26	579 36 06-01	BRACKET	w/o 5th Wheel	1	
27	501 70 37-01	BRACKET	w/ 5th Wheel	1	
27	579 36 09-01	BRACKET	w/o 5th Wheel	1	
28	585 23 59-01	SCREW EHHFM		4	
29	576 65 48-04	SCREW EHHFM	with 1 Weight	2	
29	576 65 48-06	SCREW EHHFM	with 2 Weights	2	
30	732 25 22-01	HEXAGON LOCKING NUT		2	

D FS7000DL
BASEPLATE 48"

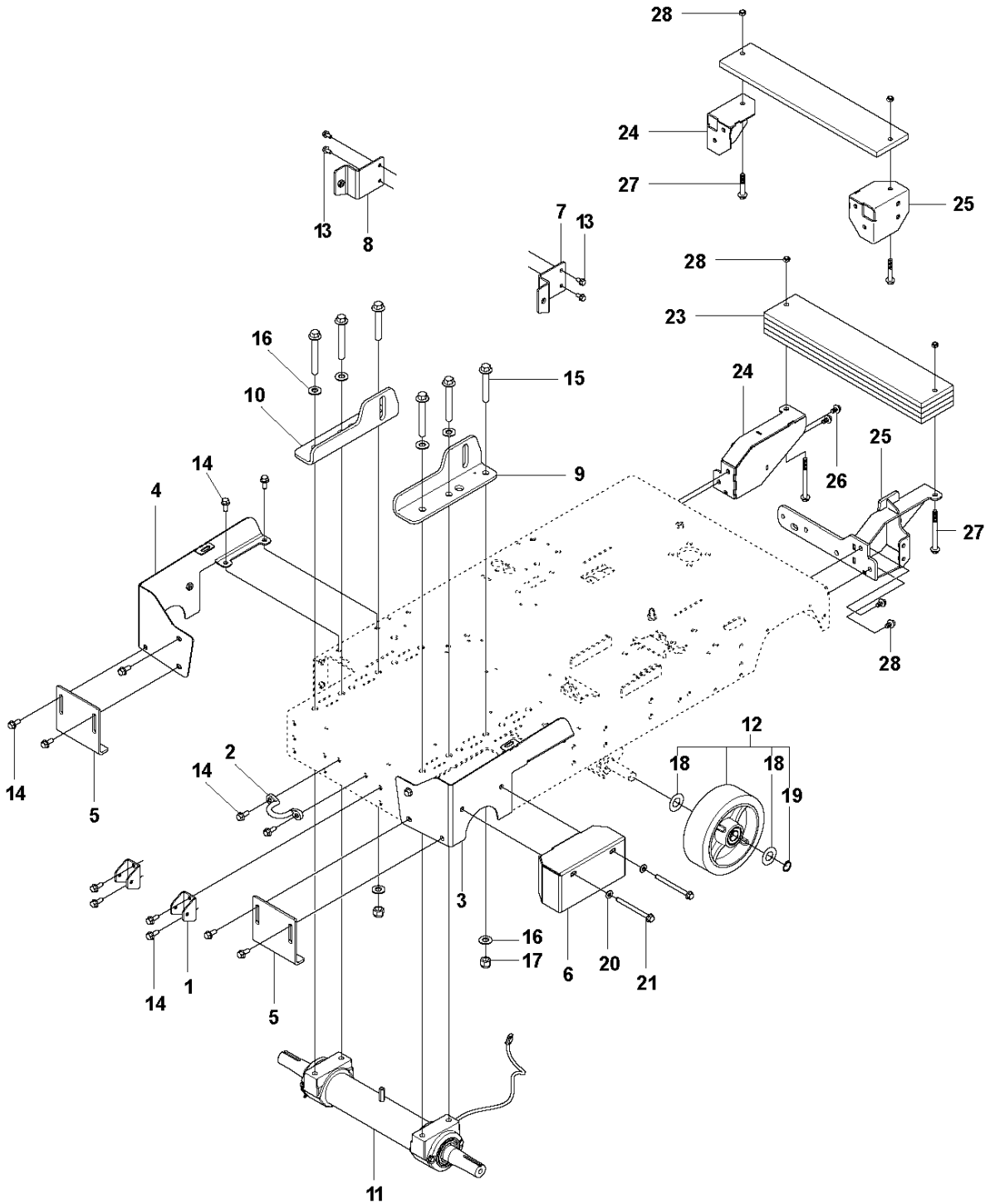

Ref	Part No	Description	Remark	QTY	KIT
1	579 35 94-01	BRACKET		2	
2	504 58 03-02	LOOP		1	
3	582 01 19-01	BRACKET		1	
4	582 01 24-01	BRACKET		1	
5	588 83 21-01	GUARD		2	
6	541 20 84-35	BRACKET		1	
7	582 19 99-01	BRACKET		1	
8	582 19 97-01	BRACKET		1	
9	501 87 14-01	ENGINE		1	
10	501 87 15-01	ENGINE		1	
11	590 19 83-01	BLADE SHAFT		1	
12	590 19 85-01	WHEEL		1	
13	585 97 56-01	SCREW EHHFM		4	
14	585 97 31-01	SCREW EHHFM		16	
15	581 24 94-02	SCREW EHHFM		6	
16	539 97 69-82	WASHER		6	
17	576 87 89-28	NUT		2	
18	542 04 64-02	WASHER		4	12
19	735 31 26-01	CIRCLIP		2	12
20	734 11 72-01	WASHER		2	
21	725 25 15-51	SCREW EHHM		2	
23	579 36 00-02	WEIGHT	1 speed or 3-speed w/ 5th Wheel	3	
23	579 36 00-02	WEIGHT	3-speed w/o 5th Wheel	4	
24	501 70 44-01	BRACKET	w/ 5th Wheel	1	
24	579 36 06-01	BRACKET	w/o 5th Wheel	1	
25	501 70 37-01	BRACKET	w/ 5th Wheel	1	
25	579 36 09-01	BRACKET	w/o 5th Wheel	1	
26	585 23 59-01	SCREW EHHFM		4	
27	576 65 48-04	SCREW EHHFM	with 1 Weight	2	
27	576 65 48-11	SCREW EHHFM	with 4 Weights	2	
28	732 25 22-01	HEXAGON LOCKING NUT		2	

E FS7000DL
BASEPLATE 60"

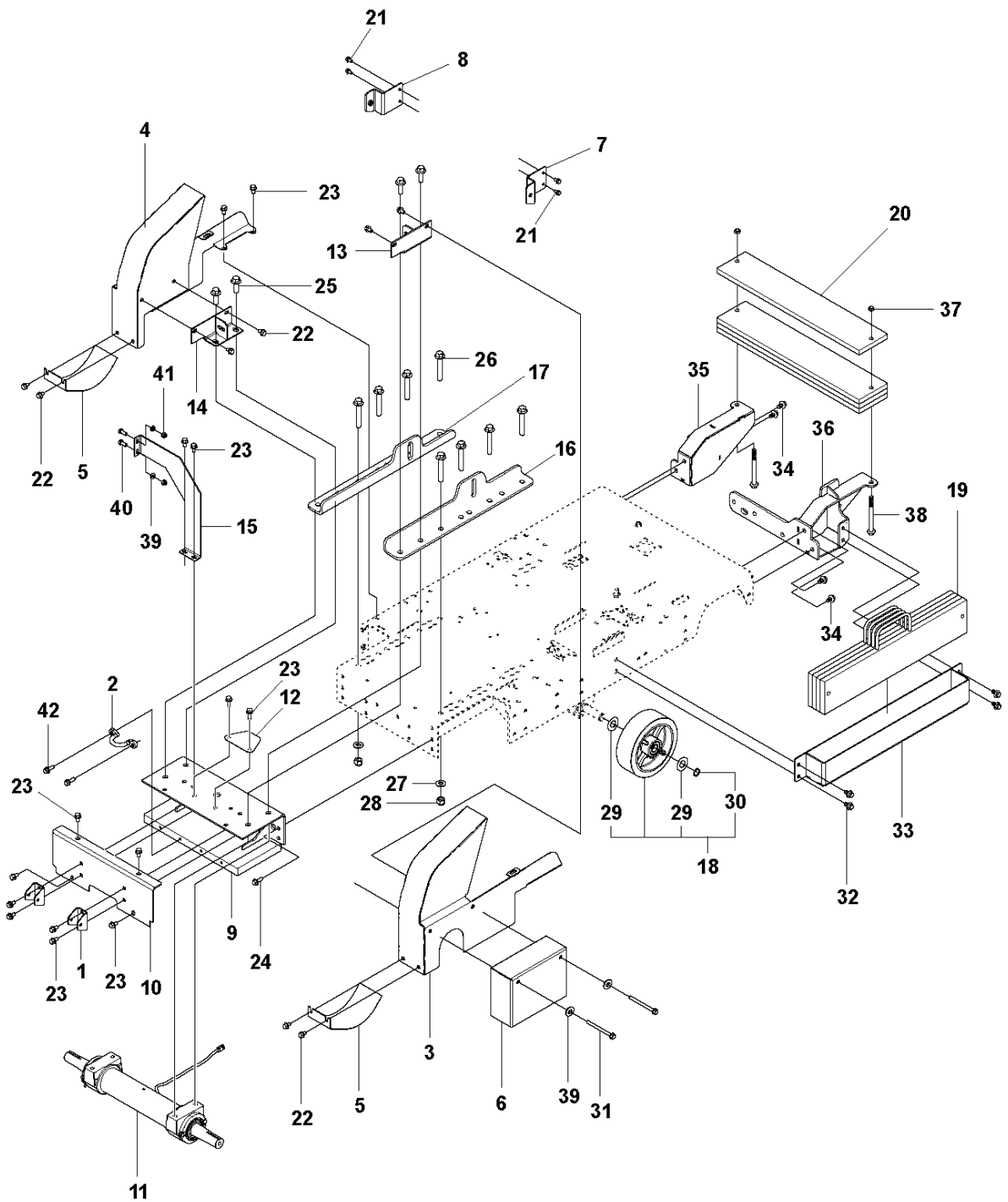

Ref	Part No	Description	Remark	QTY	KIT
1	579 35 94-01	BRACKET		2	
2	504 58 03-02	LOOP		1	
3	582 03 09-01	BRACKET		1	
4	582 02 15-01	BRACKET		1	
5	542 19 97-23	GUARD		2	
6	502 53 13-01	FLANGE		1	
7	582 19 99-01	BRACKET		1	
8	582 19 97-01	BRACKET		2	
9	582 38 16-01	BRACKET		1	
10	582 20 18-01	LID ASSY		1	
11	590 19 86-01	BLADE SHAFT		1	
12	582 20 42-01	PLATE		1	
13	582 91 72-01	GUIDE BAR		1	
14	582 91 73-01	GUIDE BAR		1	
15	502 86 02-01	BRACKET		1	
16	582 01 04-01	BRACKET		1	
17	582 01 03-01	BRACKET		1	
18	590 19 85-01	WHEEL		1	
19	579 36 01-01	WEIGHT		4	
20	579 36 00-02	WEIGHT		4	
21	585 97 56-01	SCREW EHHFM		4	
22	585 99 73-01	SCREW EHHFM		8	
23	585 97 52-01	SCREW EHHFM		16	
24	585 98 04-01	SCREW EHHFM		6	
25	581 24 94-03	SCREW EHHFM		4	
26	581 24 94-02	SCREW EHHFM		8	
27	539 97 69-82	WASHER		8	
28	576 87 89-28	NUT		8	
29	542 04 64-02	WASHER		4	18
30	735 31 26-01	CIRCLIP		2	18
31	725 25 15-51	SCREW EHHM		2	
32	576 65 48-02	SCREW EHHFM		4	
33	579 36 02-01	BOX		1	
34	585 23 59-01	SCREW EHHFM		4	
35	501 70 44-01	BRACKET		1	
36	501 70 37-01	BRACKET		1	
37	732 25 22-01	HEXAGON LOCKING NUT		2	
38	576 65 48-11	SCREW EHHFM		2	
39	734 11 72-01	WASHER		4	
40	725 24 93-71	SCREW EHHM		2	
41	732 25 20-01	HEXAGON LOCKING NUT		2	
42	585 97 31-01	SCREW EHHFM		2	

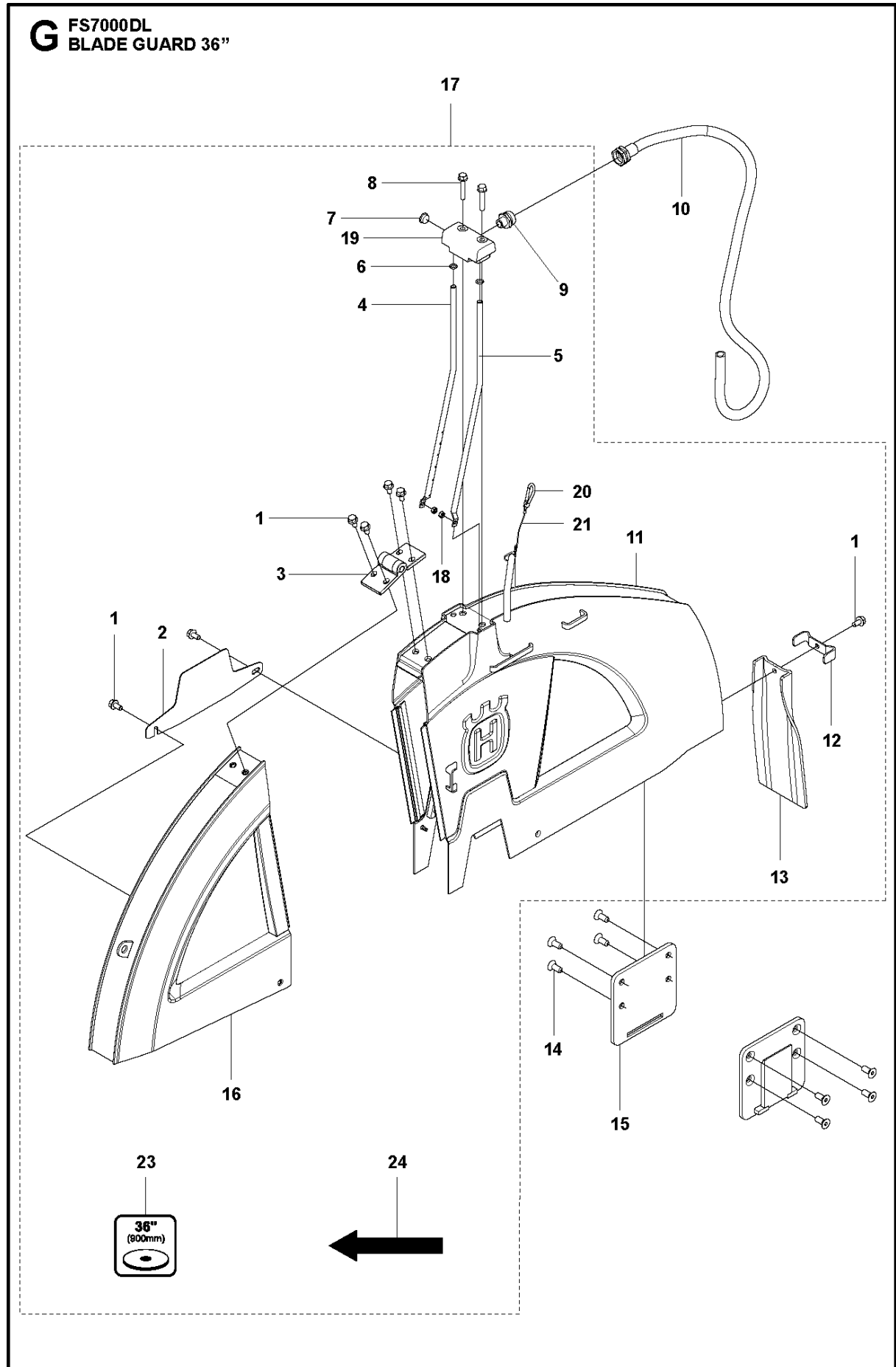

Ref	Part No	Description	Remark	QTY	KIT
1	585 97 54-01	SCREW EHHFM		7	17
2	581 34 29-01	BLADE GUARD		1	17
3	582 29 87-01	HINGE		1	17
4	581 30 63-01	PIPE		1	17
5	581 30 62-01	PIPE		1	17
6	740 43 07-00	O-RING		2	17
7	581 16 04-01	PLUG		1	17
8	585 17 39-01	SCREW EHHFM		2	17
9	541 20 82-96	HYD FIT.. 4024-12-6		1	
10	584 90 45-02	HOSE		1	17
11	582 37 26-01	BLADE GUARD		1	17
12	581 60 30-01	PLATE		1	17
13	581 60 51-01	SPLASH GUARD		1	17
14	725 64 93-51	SCREW IHCSFM		8	
15	579 60 83-01	BRACKET		2	
16	582 78 18-01	BLADE GUARD		1	17
17	590 19 93-01	BLADE GUARD	Including decals	1	
18	732 25 16-01	HEXAGON LOCKING NUT		2	17
19	581 15 72-01	MANIFOLD		1	17
20	582 58 88-01	HOOK		1	17
21	582 74 44-01	WIRE		1	17
23	586 30 78-01	DECAL		1	17
24	585 40 72-01	DECAL		1	17

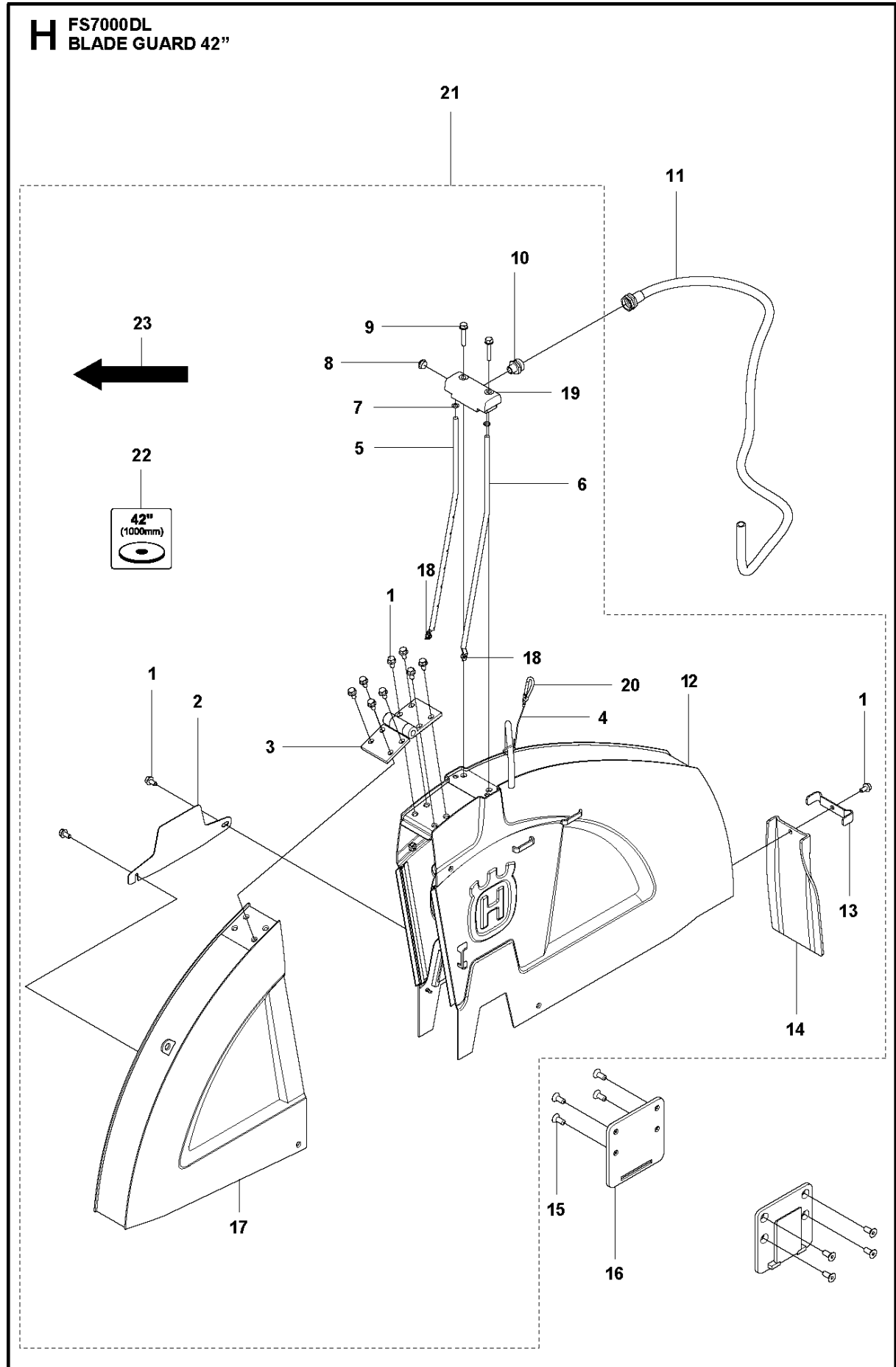

Ref	Part No	Description	Remark	QTY	KIT
1	585 97 54-01	SCREW EHHFM		11	21
2	581 34 29-01	BLADE GUARD		1	21
3	582 29 81-01	HINGE		1	21
4	582 74 44-01	WIRE		1	21
5	581 30 65-01	PIPE		1	21
6	581 30 64-01	PIPE		1	21
7	740 43 07-00	O-RING		2	21
8	581 16 04-01	PLUG		1	21
9	585 17 39-01	SCREW EHHFM		2	21
10	541 20 82-96	HYD FIT.. 4024-12-6		1	21
11	584 90 45-02	HOSE		1	
12	582 37 27-01	BLADE GUARD		1	21
13	581 59 96-01	PLATE		1	21
14	581 60 24-01	SPLASH GUARD		1	21
15	725 64 93-51	SCREW IHCSFM		8	
16	579 60 83-01	BRACKET		2	
17	582 76 80-01	BLADE GUARD		1	21
18	732 25 16-01	HEXAGON LOCKING NUT		2	21
19	581 15 75-01	MANIFOLD		1	21
20	582 58 88-01	HOOK		1	21
21	590 19 94-01	BLADE GUARD	Including decals	1	21
22	586 30 79-01	DECAL		1	21
23	585 40 72-01	DECAL		1	21

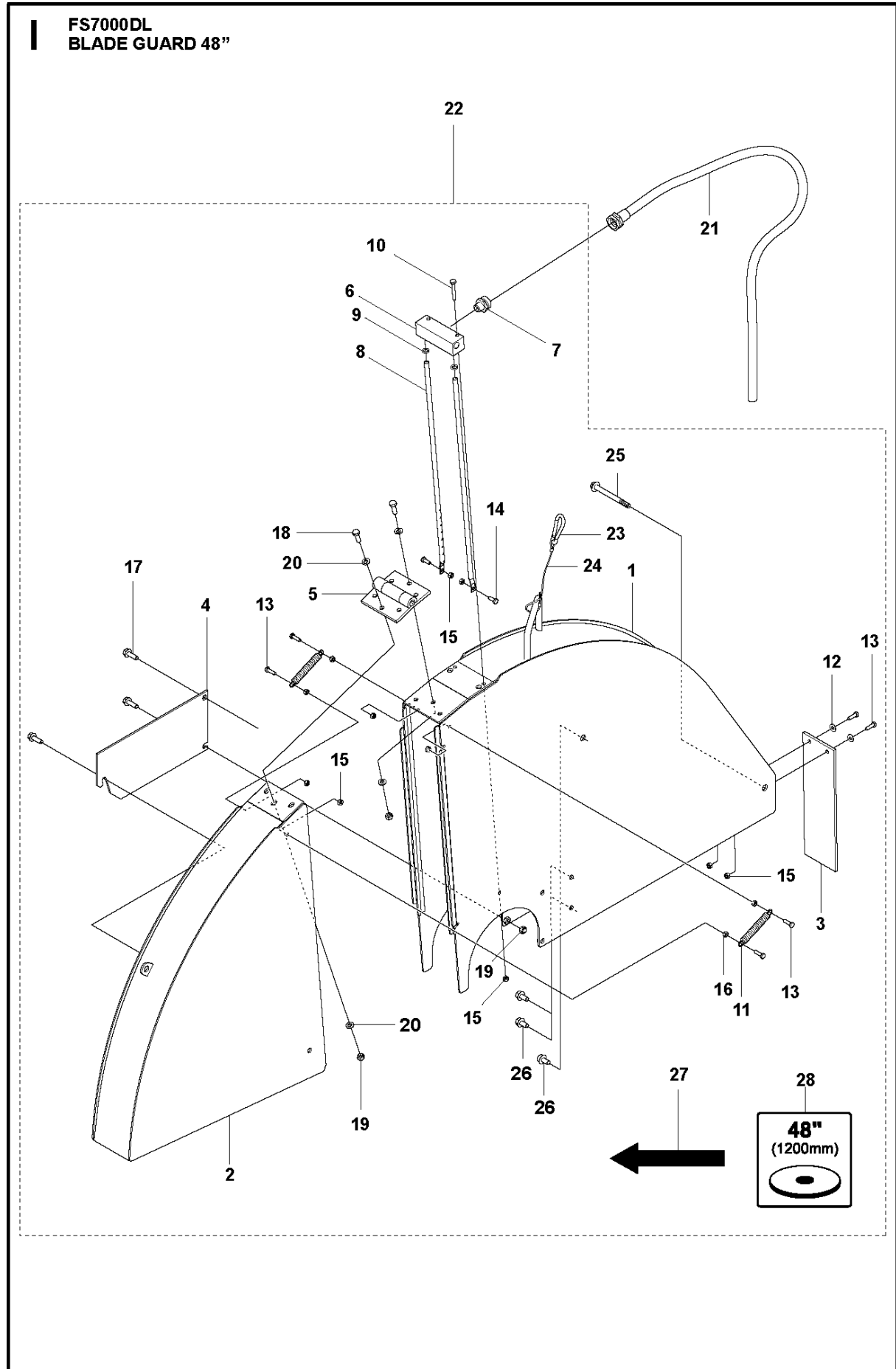

Ref	Part No	Description	Remark	QTY	KIT
1	582 17 79-01	BLADE GUARD		1	22
2	582 17 82-01	BLADE GUARD		1	22
3	542 16 32-75	SPLASH GUARD		1	22
4	541 20 84-52	LATCH		1	22
5	542 04 91-54	HINGE		1	22
6	504 00 21-01	MANIFOLD		1	22
7	541 20 82-96	HYD FIT.. 4024-12-6		1	22
8	501 04 72-02	TUBE		2	22
9	542 16 91-57	O-RING		2	22
10	725 23 79-51	SCREW EHHM		2	22
11	542 19 91-28	SPRING BLADE GUARD/FS 6600D		2	22
12	539 99 00-55	WASHER 1/4 SAE		2	22
13	725 23 70-71	SCREW EHHM		6	22
14	725 23 68-71	SCREW EHHM		2	22
15	732 25 16-01	HEXAGON LOCKING NUT		10	22
16	731 23 16-01	HEXAGON NUT		4	22
17	506 57 01-05	SCREW EHHFM		3	22
18	725 24 53-76	SCREW EHHM		6	22
19	732 25 18-01	HEXAGON LOCKING NUT		7	22
20	734 11 63-01	WASHER		12	22
21	525 39 33-01	HOSE		1	
22	590 19 95-01	BLADE GUARD	Including decals	1	22
23	582 58 88-01	HOOK		1	22
24	582 74 44-01	WIRE		1	22
25	576 65 48-12	SCREW EHHFM		1	22
26	585 99 73-01	SCREW EHHFM		3	22
27	542 16 39-86	DECAL		1	22
28	582 19 33-01	DECAL		1	22

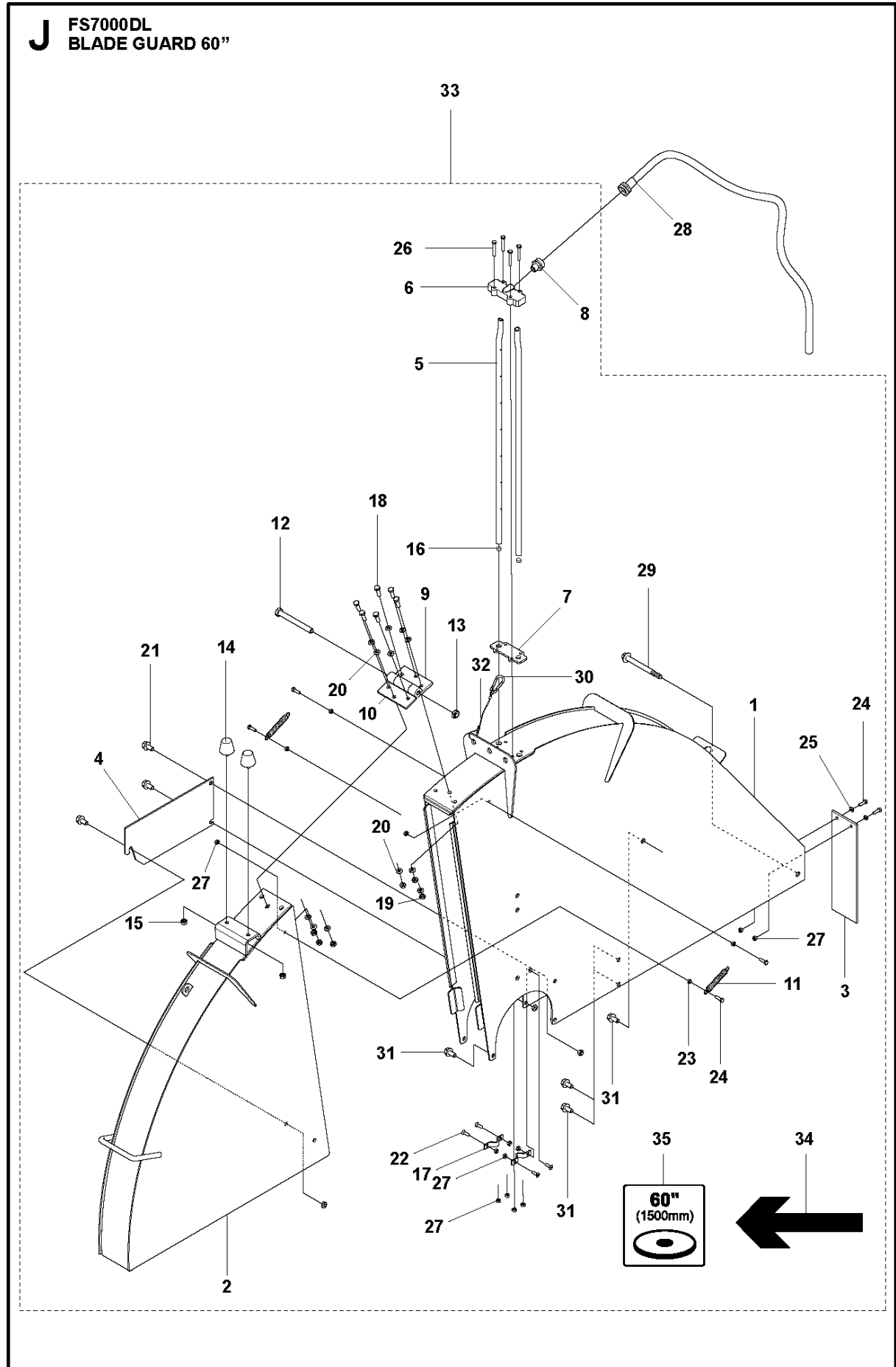

Ref	Part No	Description	Remark	QTY	KIT
1	582 18 50-01	BLADE GUARD		1	33
2	582 18 86-01	BLADE GUARD		1	33
3	542 16 32-75	SPLASH GUARD		1	33
4	541 20 84-52	LATCH		1	33
5	542 19 18-45	TUBE		2	33
6	542 04 91-96	FS902T MANIFOLD/		1	33
7	542 04 92-06	GASKET		1	33
8	541 20 82-96	HYD FIT.. 4024-12-6		1	33
9	542 19 81-03	HINGE		1	33
10	542 19 81-02	HINGE		1	33
11	542 19 91-28	SPRING BLADE GUARD/FS 6600D		2	33
12	541 20 48-85	SCREW		1	33
13	574 19 73-01	FASTENER		1	33
14	542 19 10-75	RUBBER BUMPER. IDLER STOP		2	33
15	542 03 23-66	FS900T SCREW NUT/		2	33
16	542 02 08-64	FS900T SCREW TAP/		2	33
17	542 04 92-12	FS900T SUPPORT/		2	33
18	725 24 53-71	SCREW EHHM		6	33
19	732 25 18-01	HEXAGON LOCKING NUT		7	33
20	734 11 63-01	WASHER		12	33
21	585 97 54-01	SCREW EHHFM		3	33
22	725 63 70-51	SCREW IHCSFM		4	33
23	731 23 16-01	HEXAGON NUT		4	33
24	725 23 70-71	SCREW EHHM		6	33
25	734 11 52-01	WASHER		2	33
26	725 23 78-51	SCREW EHHM		4	33
27	732 25 16-01	HEXAGON LOCKING NUT		14	33
28	525 39 33-01	HOSE		1	
29	576 65 48-12	SCREW EHHFM		1	33
30	582 58 88-01	HOOK		1	33
31	585 97 52-01	SCREW EHHFM		4	33
32	582 74 44-01	WIRE		1	33
33	590 19 96-01	BLADE GUARD	Including decals	1	33
34	542 16 39-86	DECAL		1	33
35	582 19 34-01	DECAL		1	33

T FS7000DL
BLADE SHAFT

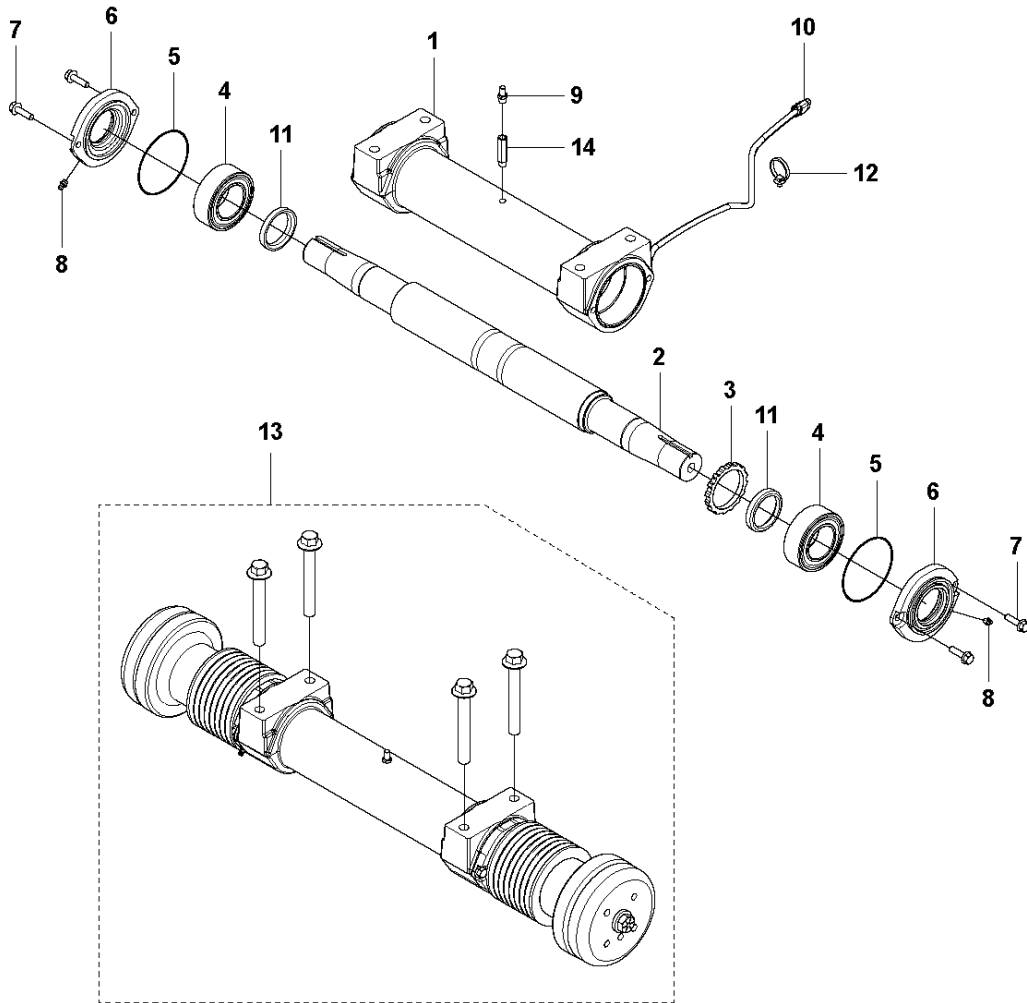

BLADE SHAFT

FS7000 DL, 2017-02

Ref	Part No	Description	Remark	QTY KIT
1	580 29 53-01	HOUSING		1
2	582 37 00-01	BLADE SHAFT		1
3	582 37 74-01	GEAR WHEEL		1
4	582 58 15-01	BEARING		2
5	580 33 80-01	O-RING		2
6	582 37 73-01	COVER		2
7	585 97 28-01	SCREW EHHFM		4
8	504 20 45-01	GREASE		2
9	580 98 11-01	SILENCER		1
10	580 98 95-01	SENSOR		1
11	582 61 06-01	SPACER		2
12	583 95 95-01	CLAMP		1
13	590 19 99-01	BLADE SHAFT	36" 3 Speed"	1
13	590 20 00-01	BLADE SHAFT	42" 3 Speed"	1
13	590 20 01-01	BLADE SHAFT	48" 3 Speed"	1
13	590 20 02-01	BLADE SHAFT	60" "	1
13	590 20 03-01	BLADE SHAFT	48" 1 Speed"	1
13	590 20 05-01	BLADE SHAFT	42" 1 Speed"	1
13	590 20 06-01	BLADE SHAFT	36" 1 Speed"	1
14	580 98 10-01	FILTER	48", 42", 36"	1

Q FS7000DL
CLUTCH

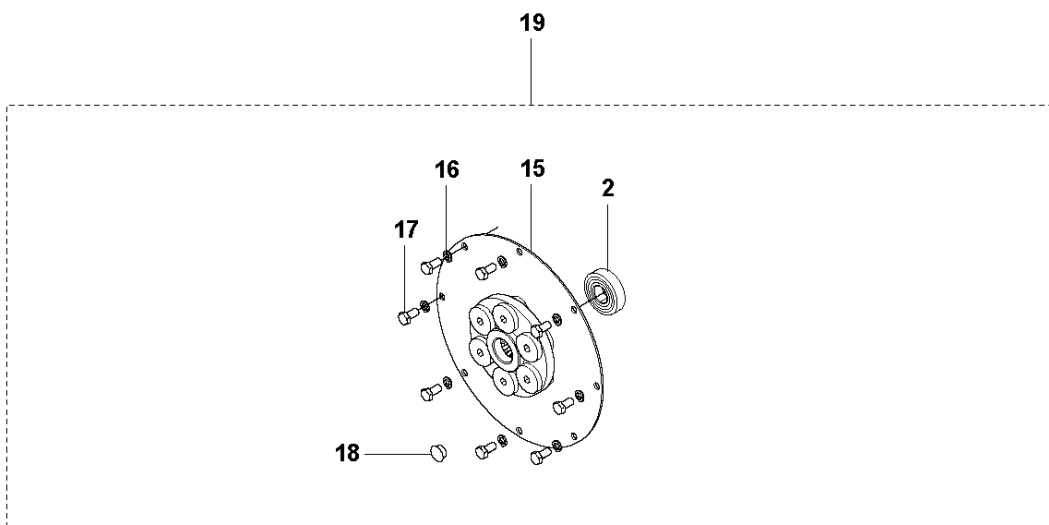
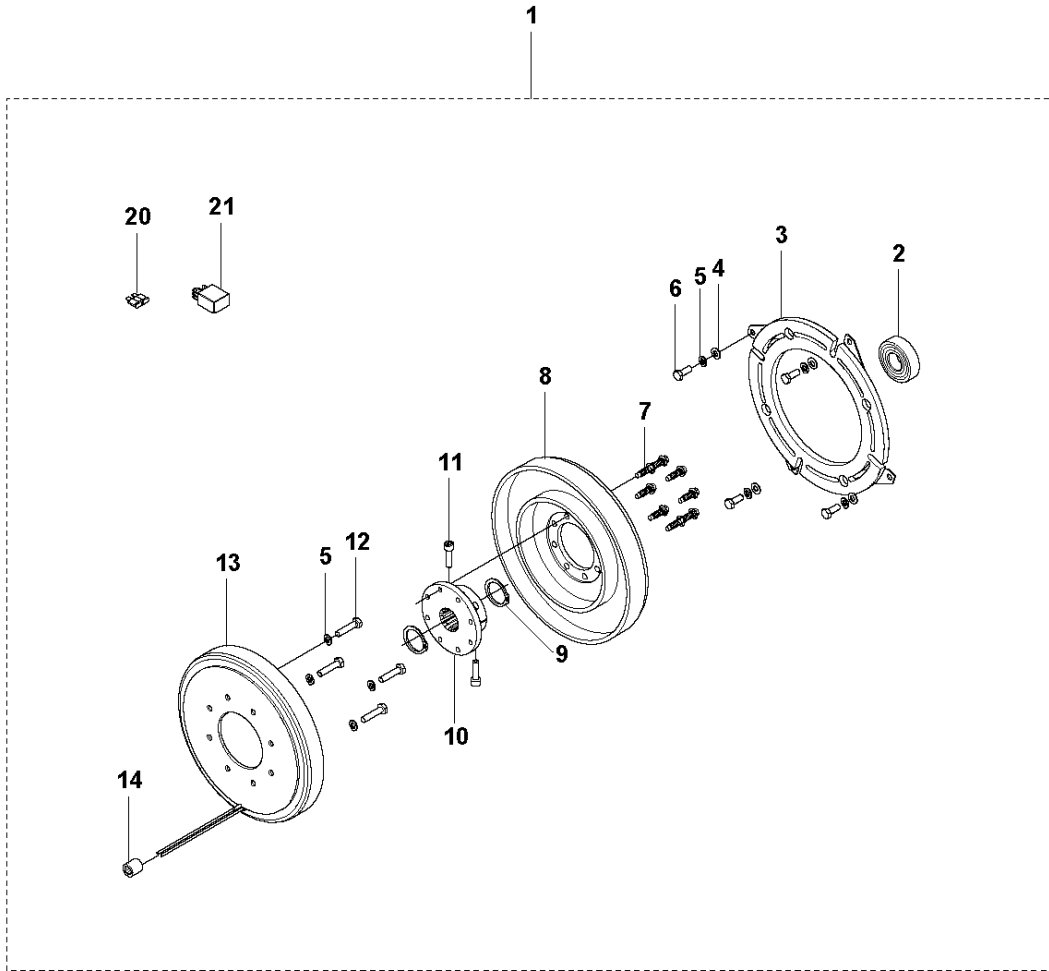

CLUTCH

FS7000 DL, 2017-02

Ref	Part No	Description	Remark	QTY	KIT
1	586 70 15-01	CLUTCH		1	
2	542 16 63-51	BEARING		1	1, 19
3	542 19 98-34	ARMATURE		1	1
4	734 11 63-01	WASHER		4	1
5	735 11 64-01	SPRING WASHER		8	1
6	725 24 51-76	SCREW EHHM		4	1
7	542 19 90-53	SCREW		8	1
8	542 16 66-85	ROTOR		1	1
9	542 19 89-53	RING		2	1
10	542 19 93-87	KUPPLUNGSNABENANTRIEB		1	1
11	725 54 55-55	SCREW IHSCM		2	1
12	725 24 57-76	SCREW EHHM		4	1
13	542 19 93-96	COIL		1	1
14	542 19 94-80	BUCHSE 1/2"ID X3/4"OD X3/4"		1	1
15	541 20 69-43	FLYWHEEL		1	19
16	735 11 73-01	SPRING WASHER		8	19
17	725 24 91-76	SCREW EHHM		8	19
18	542 18 33-75	HOLE. PLUG: 3/4"		1	19
19	586 70 85-01	COUPLING		1	
20	531 30 24-19	FUSE		1	1
21	581 07 45-01	RELAY		1	1

Y FS7000DL
CONTROL PANEL

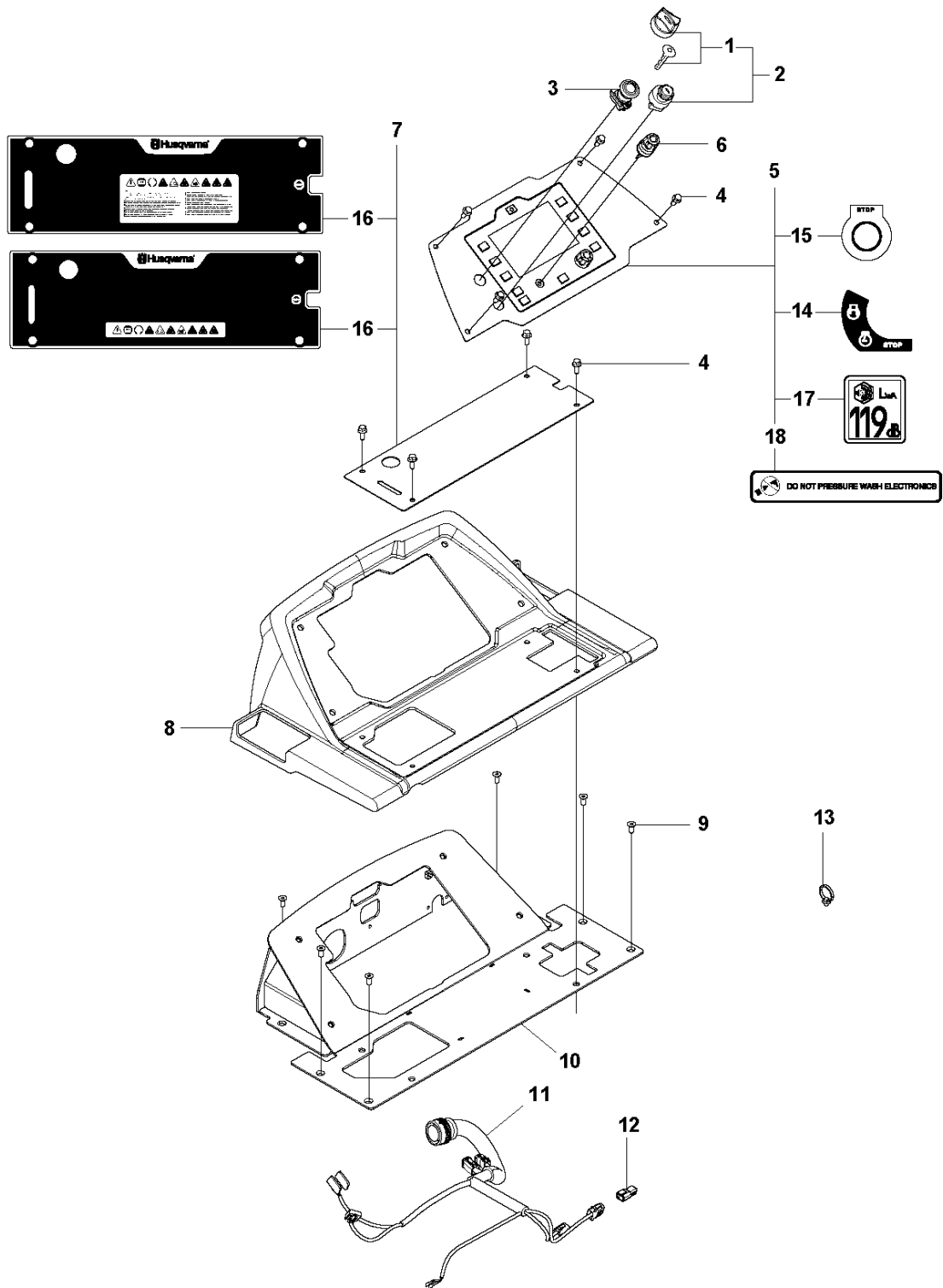

CONTROL PANEL

FS7000 DL, 2017-02

Ref	Part No	Description	Remark	QTY KIT	
1	587 68 10-01	IGNITION SWITCH		1	
2	587 68 10-01	IGNITION SWITCH	1+2 together	1	
3	586 63 78-01	STOP SWITCH		1	
4	542 19 90-53	SCREW		8	
5	589 39 20-01	CONTROL PANEL	Incl. Decals	1	
6	587 70 42-01	KNOB		2	
7	586 83 13-01	PANEL	Incl. Decals, US only	1	
7	586 83 15-01	PANEL	Incl. Decals, EU only	1	
8	580 89 13-01	COVER		1	
9	725 64 51-51	SCREW IHCSFM		6	
10	580 86 70-01	BRACKET		1	
11	586 63 98-01	HARNESS ASSY		1	
12	588 52 26-01	HARNESS		1	
13	583 95 95-01	CLAMP		6	
14	585 37 16-01	DECAL		1	5
15	585 40 71-01	DECAL		1	5
16	585 24 90-01	DECAL	US	1	7
16	585 24 88-01	DECAL	EU	1	7
17	542 19 60-29	DECAL		1	5
18	581 79 01-01	DECAL		1	5

N FS7000DL
COVER

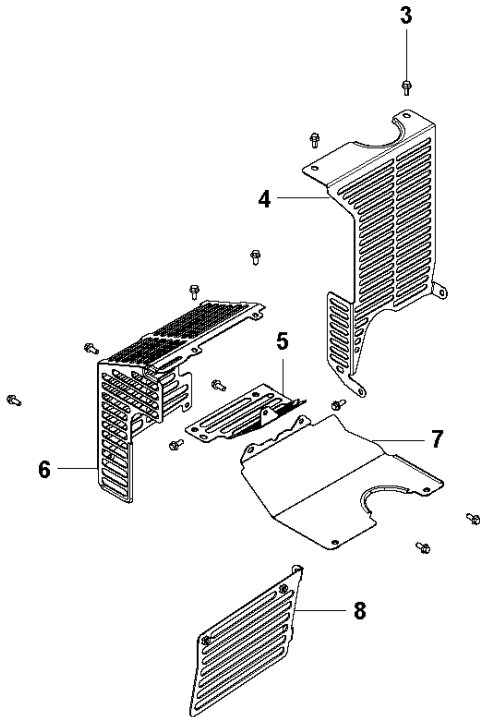
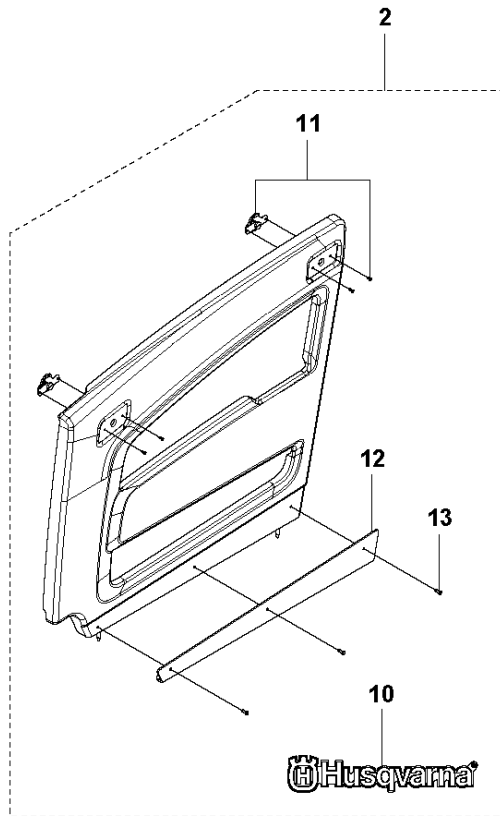
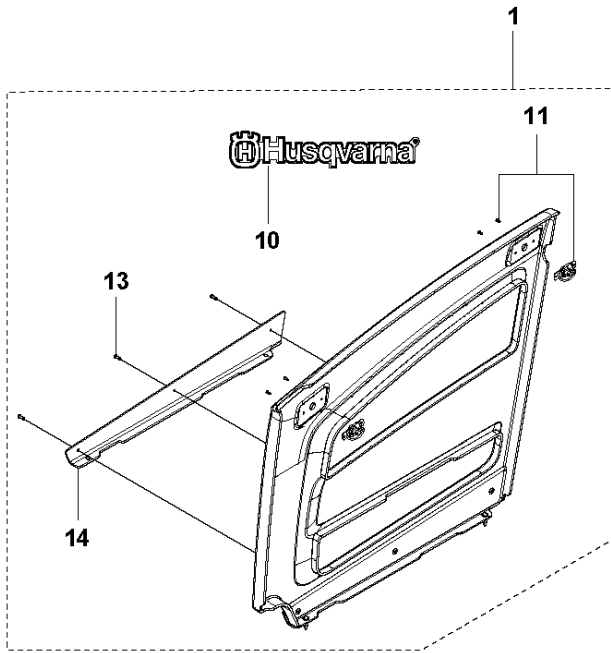

COVER

FS7000 DL, 2017-02

Ref	Part No	Description	Remark	QTY KIT	
1	586 61 49-01	COVER	Right side	1	
2	586 61 50-01	COVER	Left side	1	
3	585 97 56-01	SCREW EHHFM		17	
4	586 06 82-01	PROTECTION		1	
5	585 07 59-01	PROTECTION		1	
6	586 06 83-01	PROTECTION		1	
7	586 06 84-01	BRACKET		1	
8	585 07 65-01	PROTECTION		1	
10	585 29 48-01	DECAL		2	1, 2
11	586 61 48-01	LATCH		4	1, 2
12	580 82 92-01	COVER		1	2
13	585 17 22-01	RIVET		6	1,2
14	580 82 95-01	COVER		1	1

M FS7000DL
COVER

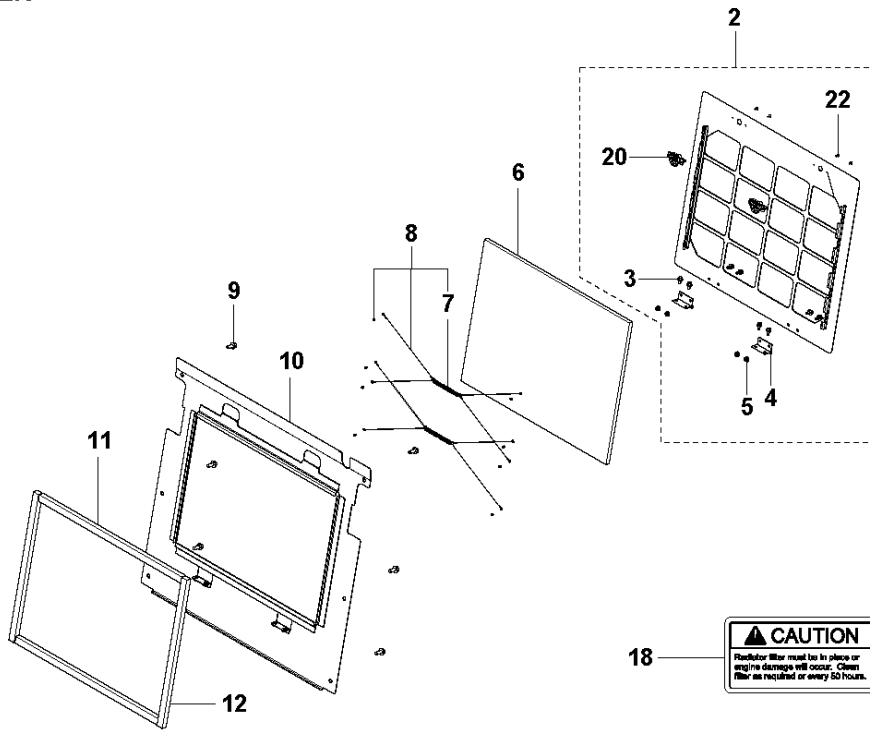

CAUTION
Radiator filter must be in place or engine damage will occur. Clean filter as required or every 50 hours.

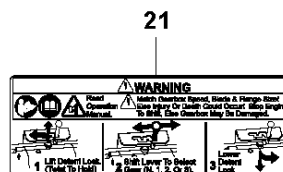
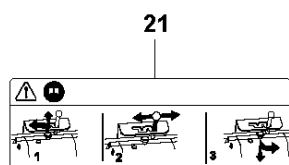
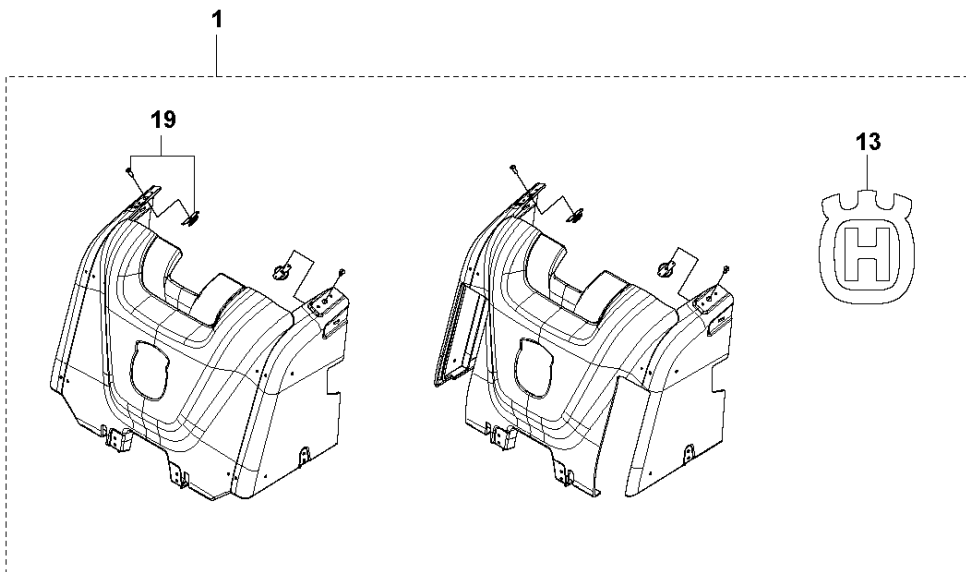

COVER

FS7000 DL, 2017-02

Ref	Part No	Description	Remark	QTY	KIT
1	590 19 97-01	FRONT COVER	60"	1	
1	590 19 98-01	FRONT COVER	36"-48"	1	
2	586 61 72-01	PLATE		1	
3	585 97 33-01	SCREW EHHFM		8	2
4	581 16 67-01	HINGE		2	2
5	731 71 16-51	HEXAGON NUT FLANGE		4	2
6	583 89 32-01	FILTER		1	
7	542 04 03-30	SPRING		2	
8	586 61 52-01	RETAINER		2	
9	585 97 54-01	SCREW EHHFM		6	
10	580 83 98-01	PLATE		1	
11	581 17 53-03	INSULATOR		2	
12	581 17 53-02	INSULATOR		2	
13	585 94 93-01	DECAL		1	1
18	542 16 68-53	DECAL	US only	1	
19	586 61 48-01	LATCH		2	1
20	521 97 35-82	ACCESSORIES		2	2
21	587 20 10-01	DECAL	EU Not Included in Kit	1	
21	587 20 11-01	DECAL	US Not Included in Kit	1	
22	722 79 23-09	RIVET		4	2

AE FS7000DL
DECALS

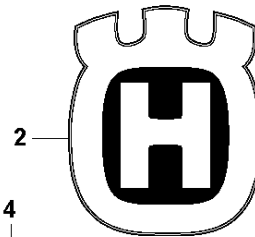

FS 7000 DL

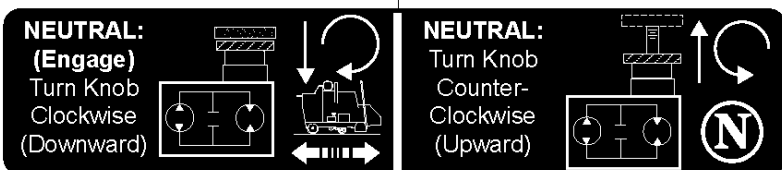
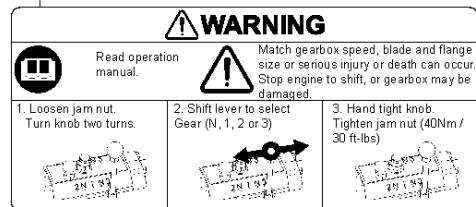
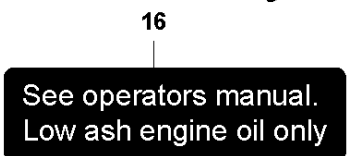
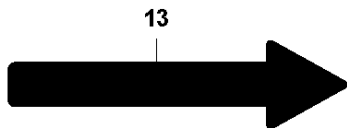
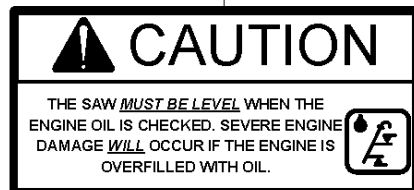
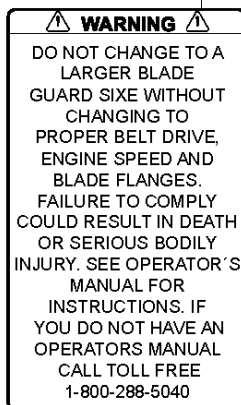
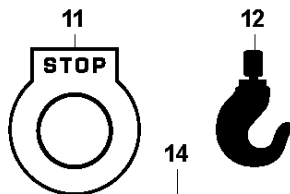
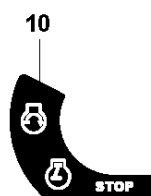
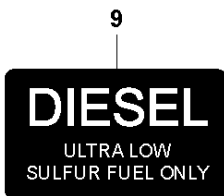
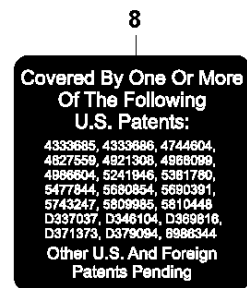
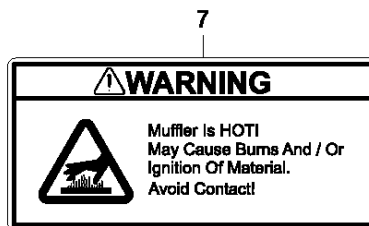
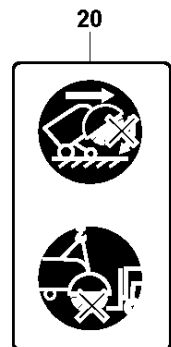
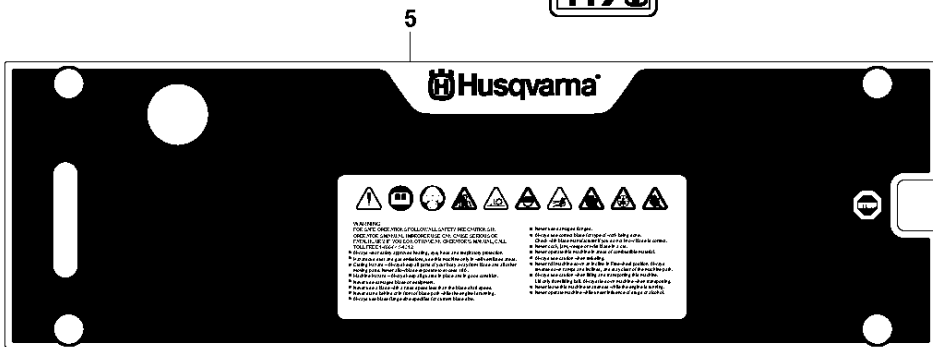

DECALS

FS7000 DL, 2017-02

Ref	Part No	Description	Remark	QTY KIT
1	585 29 48-01	DECAL		2
2	585 94 93-01	DECAL		1
3	582 41 86-01	DECAL		2
4	581 79 01-01	DECAL		1
5	585 24 90-01	DECAL	US	1
5	585 24 88-01	DECAL	EU	1
6	542 17 62-23	DECAL		3
7	542 16 90-65	DECAL	US	1
7	585 37 06-01	DECAL	EU	1
8	542 18 04-27	DECAL		1
9	585 37 04-01	DECAL	US	1
9	542 18 10-59	DECAL	EU	1
10	585 37 16-01	DECAL		1
11	585 40 71-01	DECAL		1
12	525 51 27-01	STICKER		1
13	585 40 72-01	DECAL		1
14	585 29 95-01	DECAL		1
15	521 88 53-02	DECAL	US	1
15	586 46 75-01	DECAL	EU	1
16	586 17 51-01	DECAL		1
17	542 19 06-28	DECAL	US	1
17	585 29 97-01	DECAL	EU	1
18	587 20 11-01	DECAL	US	1
18	587 20 10-01	DECAL	EU	1
19	542 16 68-53	DECAL		1
20	542 19 60-29	DECAL		1
21	589 37 02-01	DECAL		1

**FS7000DL
ELECTRICAL**

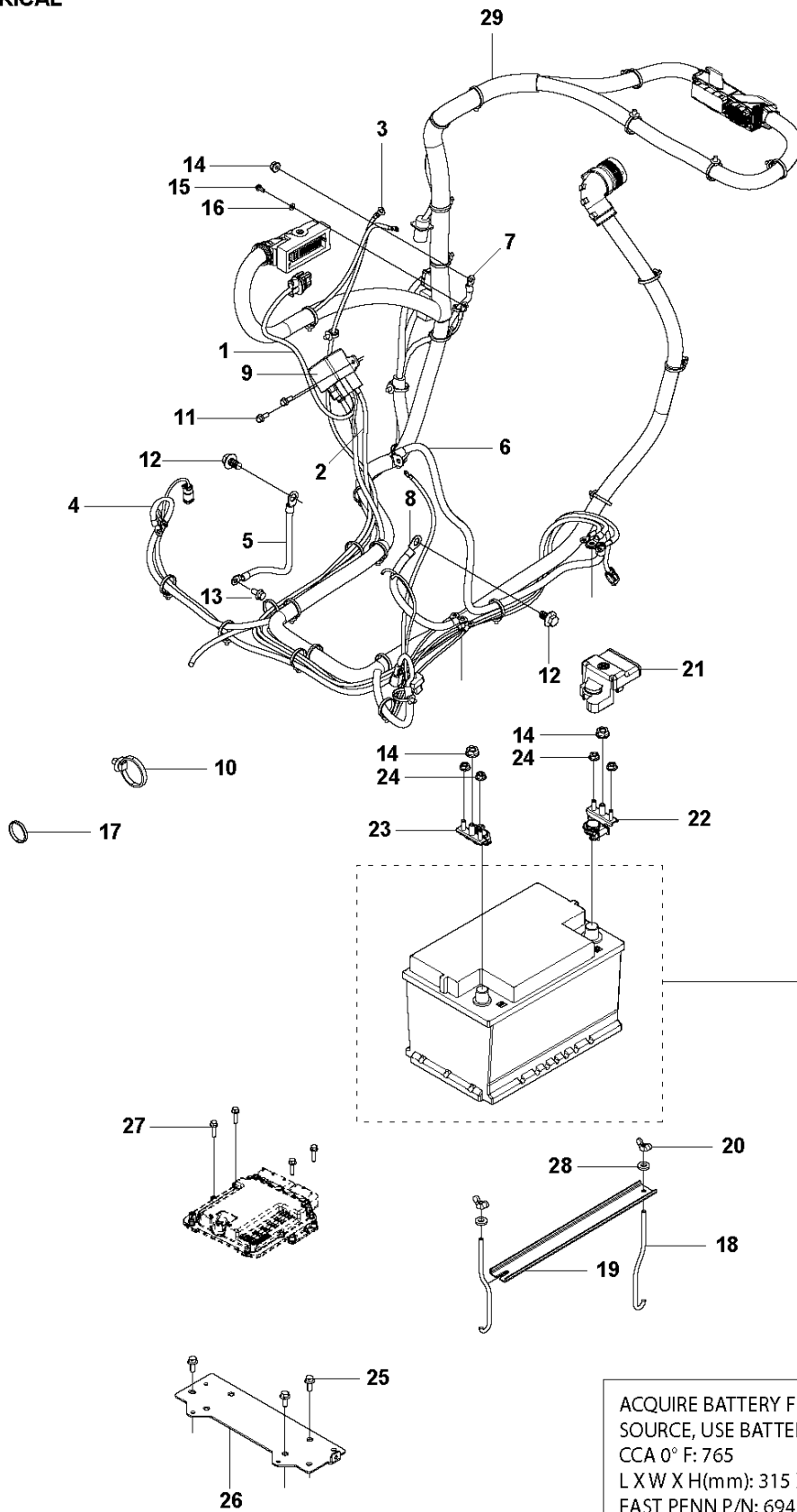

ACQUIRE BATTERY FROM LOCAL SOURCE, USE BATTERY TYPE CCA 0° F: 765
 L X W X H(mm): 315 X 175 X 190
 EAST PENN P/N: 694RMF
 BCI#: 94R
 BATTERY, 12V - 765 CCA

ELECTRICAL

FS7000 DL, 2017-02

Ref	Part No	Description	Remark	QTY KIT
1	581 07 32-01	HARNESS ASSY		1
2	581 07 32-02	HARNESS ASSY		1
3	581 07 32-03	HARNESS ASSY		1
4	581 07 32-04	HARNESS ASSY		1
5	581 07 32-05	HARNESS ASSY		1
6	581 07 32-07	HARNESS ASSY		1
7	581 07 32-11	HARNESS ASSY		1
8	581 07 32-13	HARNESS ASSY		1
9	581 07 47-01	RELAY		1
10	583 95 95-01	CLAMP		33
11	585 98 06-01	SCREW EHHFM		2
12	576 65 48-02	SCREW EHHFM		2
13	585 97 56-01	SCREW EHHFM		1
14	731 71 18-51	HEXAGON NUT FLANGE		3
15	725 23 27-71	SCREW EHHM		1
16	734 11 46-01	WASHER		1
17	542 16 69-06	TIE WRAP		3
18	584 65 09-01	BOLT		2
19	581 15 98-02	PLATE		1
20	577 24 49-01	WING NUT		2
21	581 33 65-01	ELECTRICAL SYSTEM		1
22	581 33 63-01	ELECTRICAL SYSTEM		1
23	581 33 64-01	ELECTRICAL SYSTEM		1
24	731 71 16-51	HEXAGON NUT FLANGE		4
25	585 97 54-01	SCREW EHHFM		3
26	584 14 95-01	BRACKET		1
27	585 98 03-01	SCREW EHHFM		4
28	734 11 54-41	WASHER		2
29	590 42 21-01	WIRING ASSY		1

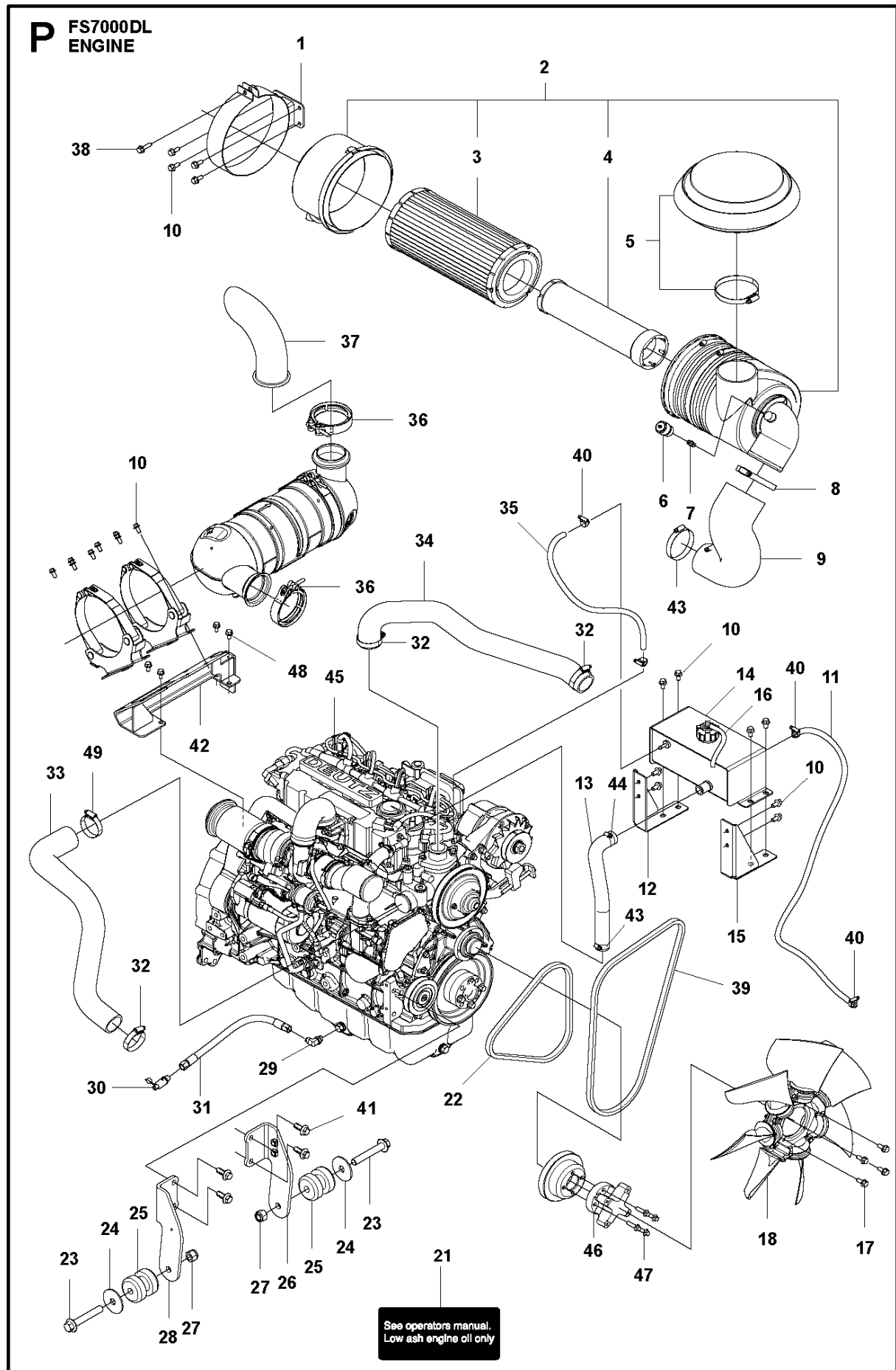

ENGINE

FS7000 DL, 2017-02

Ref	Part No	Description	Remark	QTY	KIT
1	580 95 70-01	BRACKET		1	
2	581 05 89-01	AIR CLEANER		1	
3	542 19 11-15	FILTER		1	2
4	542 19 11-16	FILTER		1	2
5	542 19 95-66	BRACKET		1	2
6	541 20 09-89	GAUGE		1	
7	542 16 68-80	ADAPTOR, RESTRICTION/INDICATOR		1	
8	576 31 52-08	HOSE CLAMP		1	
9	587 41 07-01	HOSE		1	
10	585 97 56-01	SCREW EHHFM		20	
11	585 03 71-01	TUBE		1	
12	585 02 32-01	BRACKET		1	
13	585 03 63-01	HOSE		1	
14	584 99 82-01	EXPANSION TANK		1	
15	585 02 34-01	BRACKET		1	
16	585 06 66-01	HOSE		1	
17	585 97 54-01	SCREW EHHFM		4	
18	584 82 46-01	FAN		1	
21	586 17 51-01	DECAL		1	
22	586 07 11-01	BELT		1	
23	581 24 94-02	SCREW EHHFM		2	
24	542 20 63-56	WASHER		2	
25	587 15 01-01	ANTIVIBRATION ELEMENT		2	
26	581 85 37-01	BRACKET		1	
27	576 87 89-28	NUT		2	
28	581 07 98-01	BRACKET		1	
29	581 72 73-01	ADAPTER		1	
30	542 16 69-07	VALVE		1	
31	584 97 09-01	HOSE ASSY		1	
32	576 31 52-03	HOSE CLAMP		3	
33	580 91 03-01	HOSE		1	
34	580 91 02-01	HOSE		1	
35	585 03 70-01	TUBE		1	
36	586 36 88-01	CLAMP		2	
37	581 27 49-01	EXHAUST PIPE		1	
38	585 97 28-01	SCREW EHHFM		1	
39	586 07 11-02	BELT		1	
40	542 02 00-49	HOSE CLAMP		5	
41	576 65 48-03	SCREW EHHFM		4	
42	580 95 74-01	BRACKET		1	
43	576 31 52-07	HOSE CLAMP		1	
44	576 31 52-05	HOSE CLAMP		2	
45	590 49 02-01	ENGINE		1	
46	586 62 67-01	SPACER		1	
47	586 62 68-01	SCREW		4	
48	585 97 31-01	SCREW EHHFM		4	
49	539 30 00-73	CLAMP HOSE #32 1 9/16-2 1/2M32		1	

AG FS7000DL
E-TRACK SYSTEM

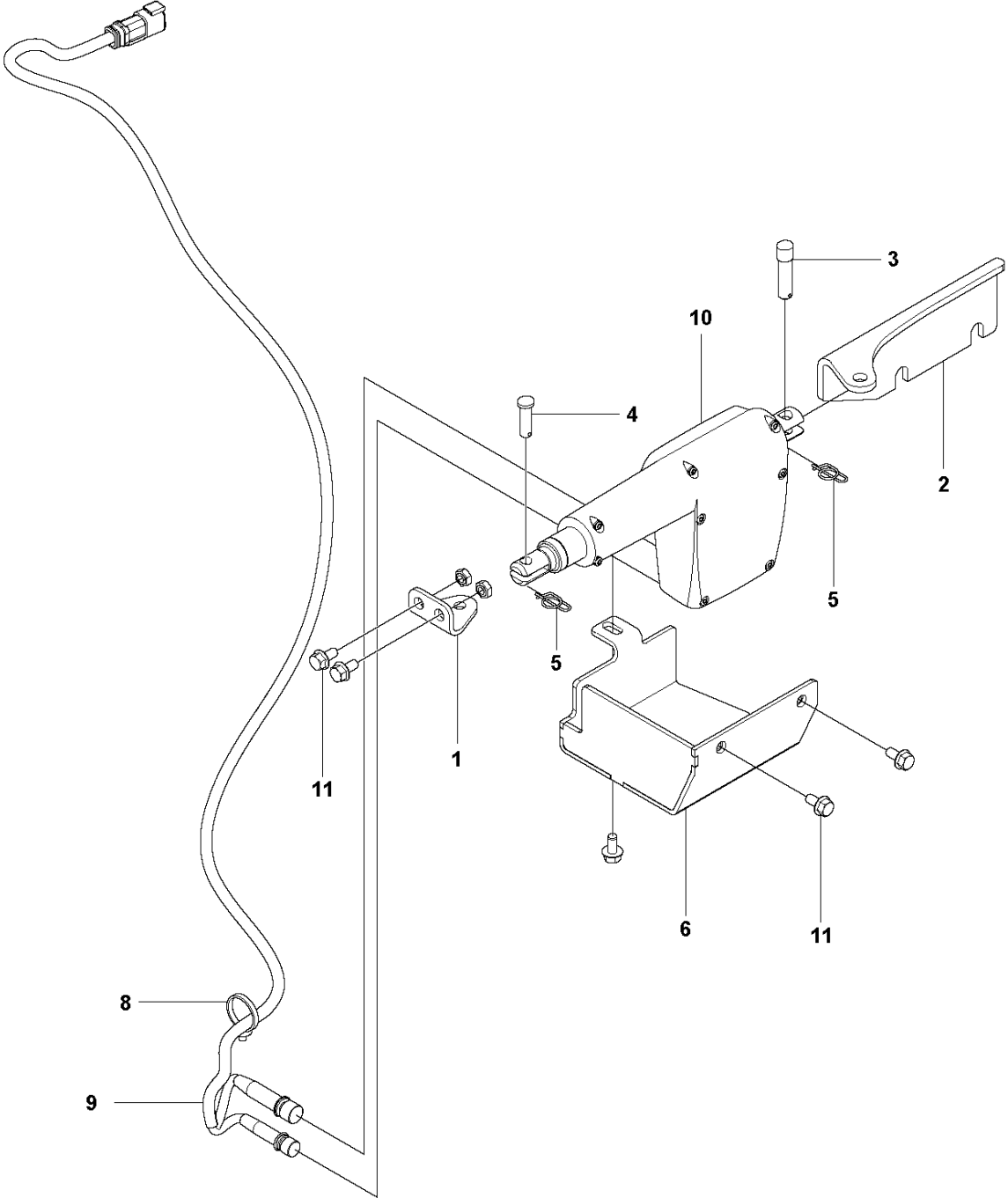

Ref	Part No	Description	Remark	QTY KIT
1	586 14 60-01	BRACKET		1
2	582 72 63-01	BRACKET		1
3	542 19 92-39	BOLT		1
4	542 19 92-41	BOLT		1
5	542 17 72-39	STIFT 1/2"		2
6	586 16 75-01	LID		1
8	583 95 95-01	CLAMP		1
9	586 16 90-01	CABLE		1
10	586 15 58-01	ACTUATOR		1
11	585 97 54-01	SCREW EHHFM		5

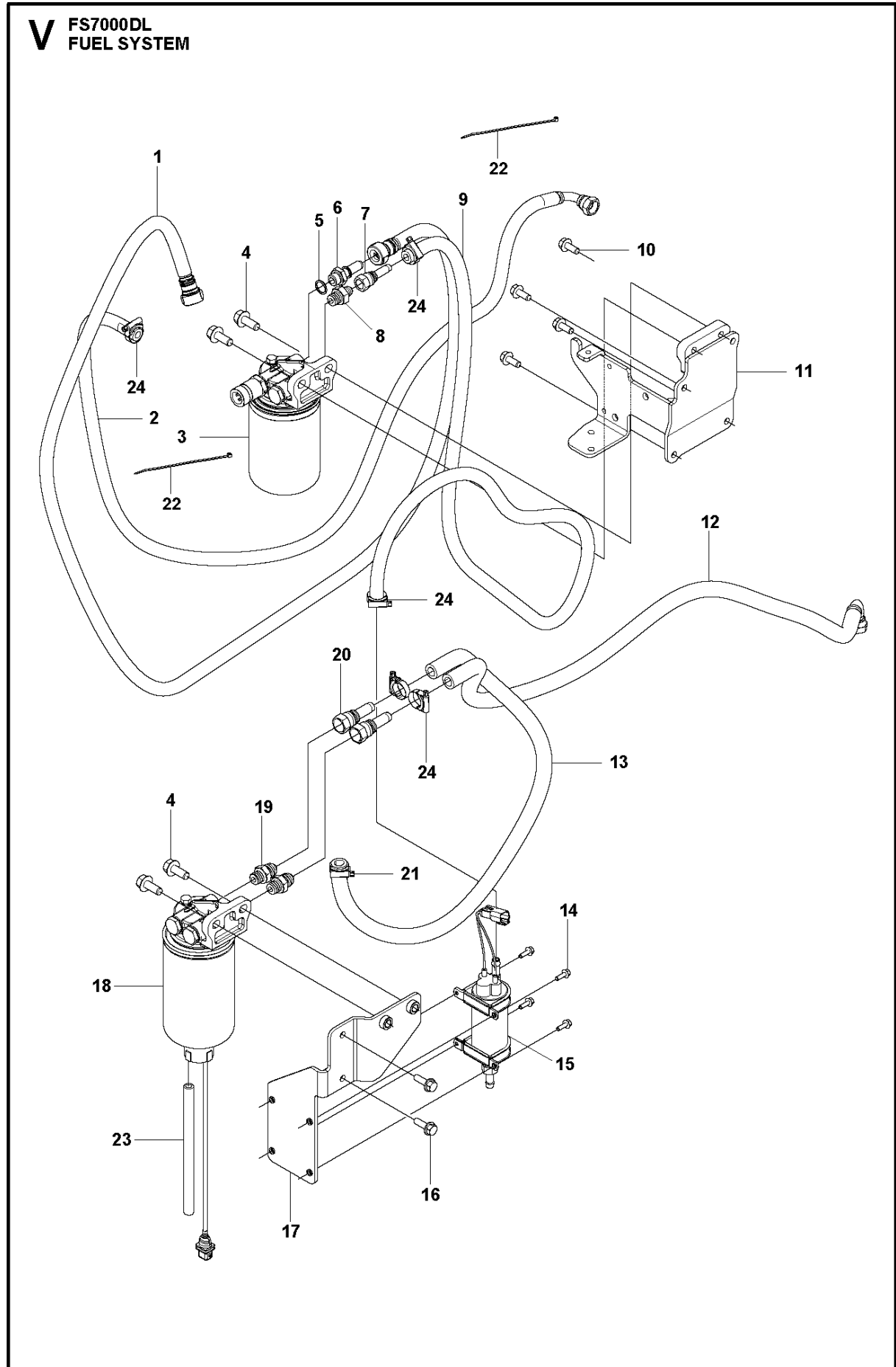

FUEL SYSTEM

FS7000 DL, 2017-02

Ref	Part No	Description	Remark	QTY KIT
1	581 22 61-01	HOSE ASSY		1
2	584 15 67-01	HOSE ASSY		1
3	581 77 71-01	FUEL FILTER		1
4	585 97 31-01	SCREW EHHFM		4
5	587 94 59-01	WASHER		1
6	587 93 65-01	FITTING		1
7	585 18 94-01	FITTING		1
8	585 18 90-01	ADAPTER		1
9	585 05 60-01	FUEL HOSE		1
10	585 97 54-01	SCREW EHHFM		4
11	580 96 95-01	BRACKET		1
12	581 22 61-01	HOSE ASSY		1
13	585 05 30-01	FUEL HOSE		1
14	585 98 05-01	SCREW EHHFM		4
15	590 54 65-01	FUEL PUMP		1
16	506 57 01-05	SCREW EHHFM		2
17	584 22 64-01	BRACKET		1
18	581 77 69-01	WATER SEPARATOR		1
19	585 18 92-01	ADAPTER		2
20	585 18 95-01	FITTING		2
21	539 30 00-11	CLAMP, HOSE, MAH-6, 5/16-7/8		3
22	542 16 62-14	TIE WRAP		2
23	585 06 66-01	HOSE		1
24	542 02 00-49	HOSE CLAMP		3

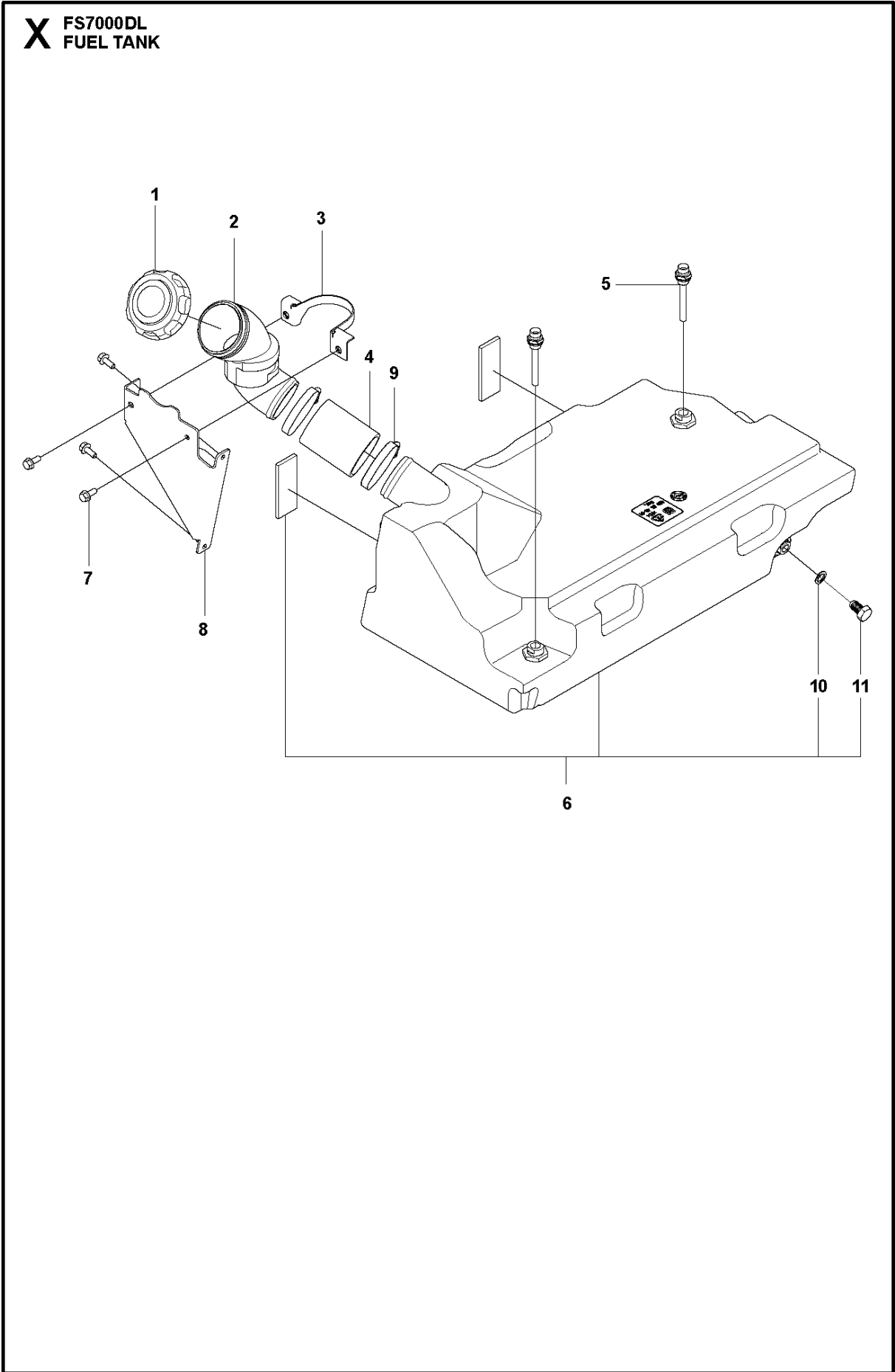

FUEL TANK

FS7000 DL, 2017-02

Ref	Part No	Description	Remark	QTY	KIT
1	539 10 63-30	TANK CAP		1	
2	587 85 61-01	PIPE		1	
3	583 91 40-01	BRACKET		1	
4	581 05 36-01	HOSE		1	
5	581 12 91-01	ADAPTER		2	
6	586 07 14-01	FUEL TANK ASSY	Incl. Insulator	1	
7	585 97 54-01	SCREW EHHFM		4	
8	583 96 68-01	BRACKET		1	
9	576 31 52-07	HOSE CLAMP		2	
10	740 38 29-01	SEALING WASHER		1	6
11	585 59 54-01	PLUG		1	6

AH FS7000DL
FUSE AND RELAYS

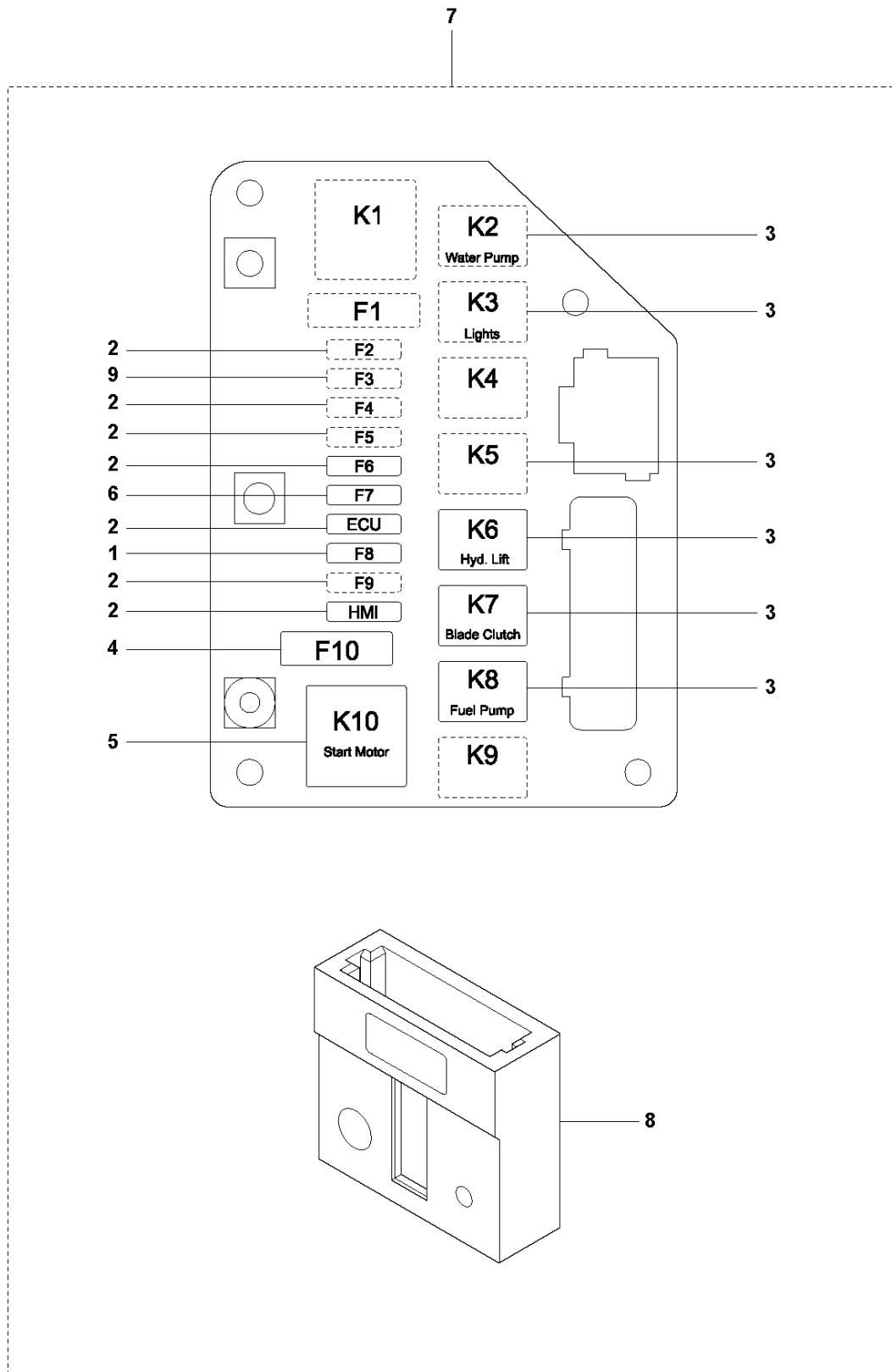

FUSE AND RELAYS

FS7000 DL, 2017-02

Ref	Part No	Description	Remark	QTY	KIT
1	531 30 24-20	FUSE	20 A Fuse	1	7
2	531 30 24-21	FUSE	25 A Fuse	7	7
3	581 07 45-01	RELAY	25 A Relay	6	
4	581 41 21-01	FUSE	60 A Fuse	1	
5	581 07 46-01	RELAY	70 A RELAY	1	
6	531 30 24-19	FUSE	15 A Fuse	1	7
7	581 33 36-01	ELECTRICAL SYSTEM		1	
8	501 69 62-01	FUSE HOLDER	Located at F2, F3, F6, ECU, F8, HMI	6	7
9	542 16 68-56	FUSE	7.5 A Fuse	1	7

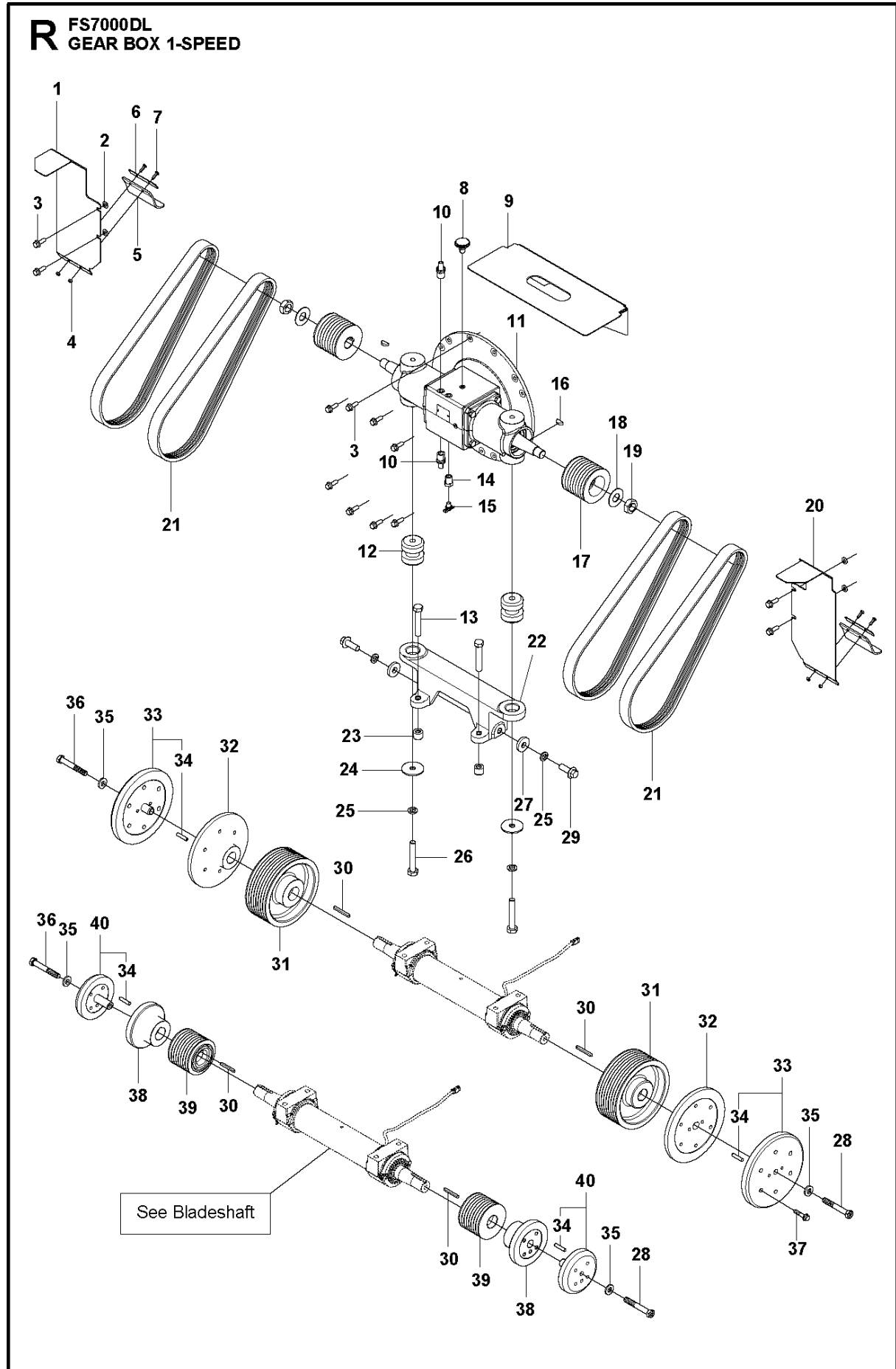

GEAR BOX 1-SPEED

FS7000 DL, 2017-02

Ref	Part No	Description	Remark	QTY KIT
1	581 02 08-01	BELT GUARD		1
2	734 11 72-01	WASHER		4
3	585 98 04-01	SCREW EHHFM		12
4	732 25 16-01	HEXAGON LOCKING NUT		4
5	581 52 16-01	SPLASH GUARD		2
6	581 52 18-01	PLATE		2
7	586 12 02-01	SCREW EHHFM		4
8	542 20 66-60	BREATHER		1
9	586 02 13-01	PROTECTION		1
10	541 20 48-70	MUFFE 12"H X1/2 MPT		2
11	588 58 87-01	GEARBOX		1
12	587 15 01-01	ANTIVIBRATION ELEMENT		2
13	542 16 63-68	SCREW		2
14	542 13 96-49	ADAPTER		1
15	542 16 07-04	HAHN 1/4"NPT		1
16	542 16 46-32	FS1200T KEY - WOODRUFF/		2
17	581 09 98-01	PULLEY		2
18	542 16 64-80	WASHER		2
19	541 20 48-33	NUT		2
20	581 02 09-01	BELT GUARD		1
21	542 19 96-99	V-BELT	36" - 48"	1
21	504 11 97-01	V-BELT	60"	4
22	542 16 64-42	BRACKET		1
23	539 30 04-40	BOLT		2
24	542 20 63-56	WASHER		2
25	539 99 03-33	WASHER		4
26	542 16 63-56	SCREW		2
27	542 16 03-93	FS900T RING/		2
28	586 25 57-01	SCREW	36" Only	1
28	586 25 60-01	SCREW	42", 48", 60"	1
29	542 16 74-47	SCREW		2
30	542 19 90-45	KEY		2
31	582 41 14-01	PULLEY	60"	2
32	582 48 74-01	FLANGE	60"	2
33	522 96 59-41	FLANGE	60" Including Pin"	2
34	539 30 00-10	PIN	36"-48"	10 40
34	539 30 00-10	PIN	60"	10 33
35	522 96 59-42	WASHER		2
36	586 25 59-01	SCREW	36" Only	1
36	586 25 61-01	SCREW	42", 48", 60"	1
37	576 65 48-04	SCREW EHHFM	60"	12
38	582 69 72-01	FLANGE	36"	2
38	582 48 70-01	FLANGE	42"	2
38	582 48 72-01	FLANGE	48"	2
39	582 41 19-01	PULLEY	36"	2
39	582 41 16-01	PULLEY	42"	2
39	582 41 15-01	PULLEY	48"	2
40	522 96 59-39	FLANGE	36" Including Pin"	2
40	522 96 59-38	FLANGE	42" Including Pin"	2
40	522 96 59-40	FLANGE	48" Including Pin"	2

S FS7000DL
GEAR BOX 3-SPEED

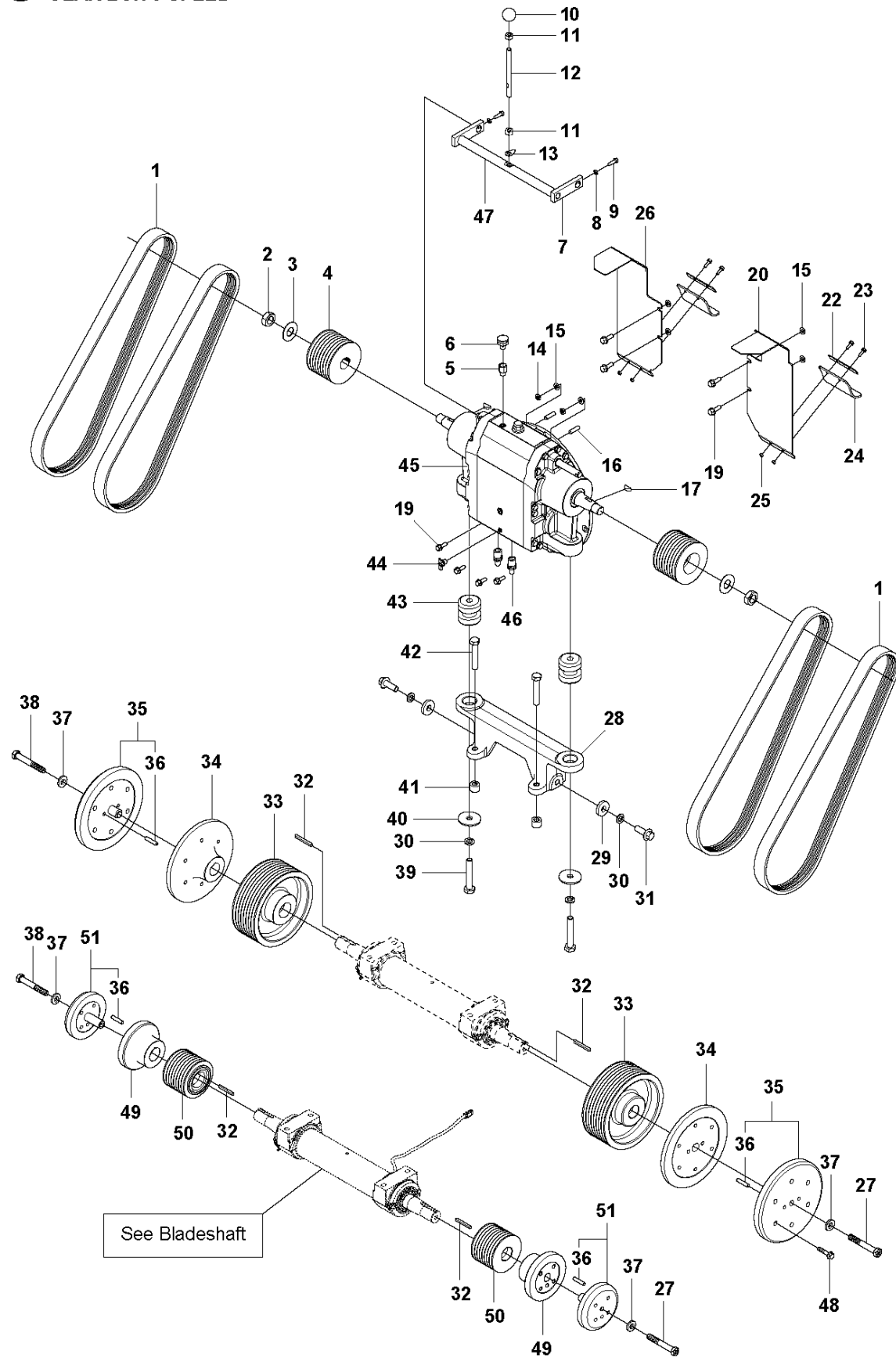

GEAR BOX 3-SPEED

FS7000 DL, 2017-02

Ref	Part No	Description	Remark	QTY	KIT
1	504 11 97-01	V-BELT	36"	4	
1	541 20 09-91	V-BELT	42"	4	
1	504 11 97-01	V-BELT	48"	4	
1	541 20 08-07	V-BELT	60"	4	
2	541 20 48-33	NUT		2	
3	542 16 64-80	WASHER		2	
4	581 09 98-02	PULLEY	36", 42", 48"	2	
4	581 09 98-03	PULLEY	60"	2	
5	504 53 75-01	FITTING		1	
6	504 53 96-01	FITTING		1	
7	586 96 49-01	ARM		1	
8	542 02 07-77	SCHEIBE 5/16		2	
9	505 77 25-01	5/16-18 X 1 SHC BLACK		2	
10	542 16 32-14	BOULE/		1	
11	539 99 02-58	NUT		2	
12	542 20 63-97	HANDLE		1	
13	586 86 52-01	POINTER		1	
14	731 43 20-01	HEXAGON THIN NUT		2	
15	734 11 72-01	WASHER		6	
16	542 20 64-16	STUD. M10 X 25MM		2	
17	542 16 46-32	FS1200T KEY - WOODRUFF/		2	
19	585 98 04-01	SCREW EHHFM		8	
20	581 02 09-01	BELT GUARD		1	
22	581 52 18-01	PLATE		2	
23	586 12 02-01	SCREW EHHFM		4	
24	581 52 16-01	SPLASH GUARD		2	
25	732 25 16-01	HEXAGON LOCKING NUT		4	
26	581 02 08-01	BELT GUARD		1	
27	586 25 57-01	SCREW	36" Only	1	
27	586 25 60-01	SCREW	42", 48", 60"	1	
28	542 16 64-42	BRACKET		1	
29	542 16 03-93	FS900T RING/		2	
30	539 99 03-33	WASHER		4	
31	542 16 74-47	SCREW		2	
32	542 19 90-45	KEY		2	
33	582 41 14-01	PULLEY	60"	2	
34	582 48 74-01	FLANGE	60"	2	
35	522 96 59-41	FLANGE	60" Including Pin"	2	
36	539 30 00-10	PIN	36", 42", 48"	10	51
36	539 30 00-10	PIN	60"	10	35
37	522 96 59-42	WASHER		2	
38	586 25 59-01	SCREW	36" Only	1	
38	586 25 61-01	SCREW	42", 48", 60"	1	
39	542 16 63-56	SCREW		2	
40	542 20 63-56	WASHER		2	
41	539 30 04-40	BOLT		2	
42	542 16 63-68	SCREW		2	
43	587 15 01-01	ANTIVIBRATION ELEMENT		2	
44	542 16 07-04	HAHN 1/4"NPT		1	
45	586 87 03-01	GEARBOX		1	
46	541 20 48-70	MUFFE 12"H X1/2 MPT		2	
47	586 85 75-01	ROD		1	
48	576 65 48-04	SCREW EHHFM	60"	12	
49	582 69 72-01	FLANGE	36"	2	
49	582 48 70-01	FLANGE	42"	2	
49	582 48 72-01	FLANGE	48"	2	
50	582 41 17-01	PULLEY	36"	2	
50	582 41 18-01	PULLEY	42"	2	
50	582 41 16-01	PULLEY	48"	2	
51	522 96 59-39	FLANGE	36" Including Pin"	2	
51	522 96 59-38	FLANGE	42" Including Pin"	2	
51	522 96 59-40	FLANGE	48" Including Pin"	2	

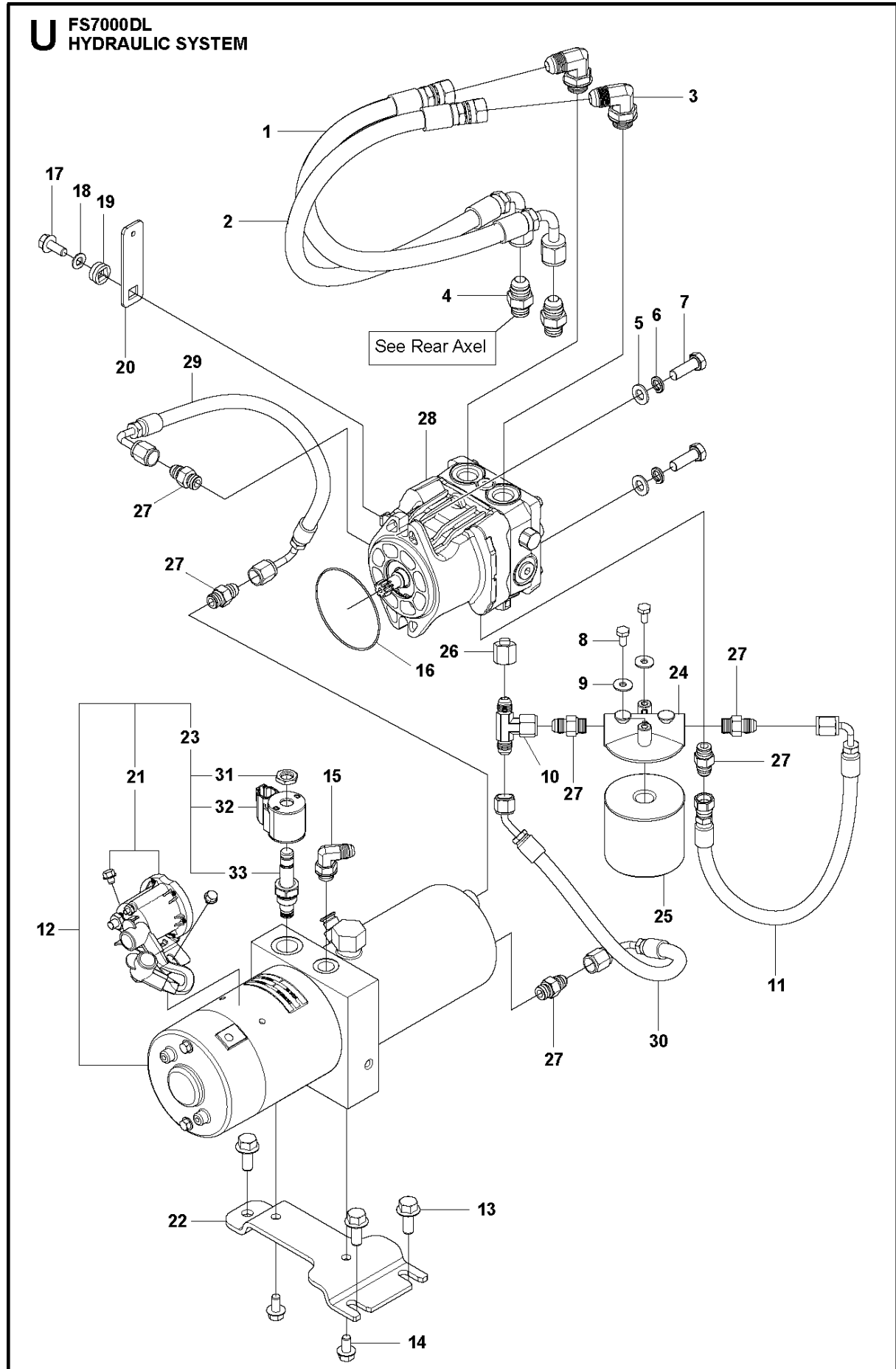

HYDRAULIC SYSTEM

FS7000 DL, 2017-02

Ref	Part No	Description	Remark	QTY	KIT
1	584 26 74-01	HYDRAULIC HOSE		1	
2	584 26 71-01	HYDRAULIC HOSE		1	
3	583 96 59-01	ADAPTER		2	
4	583 96 82-01	ADAPTER		2	
5	734 11 72-01	WASHER		2	
6	735 11 73-01	SPRING WASHER		2	
7	725 24 95-76	SCREW EHHM		2	
8	542 02 03-01	CAP SCREW ITEM 40 020301/		2	
9	734 11 54-41	WASHER		2	
10	583 96 62-02	ADAPTER		1	
11	584 27 07-01	HYDRAULIC HOSE		1	
12	588 69 06-01	HYDRAULIC PUMP		1	
13	585 97 31-01	SCREW EHHFM		3	
14	585 97 56-01	SCREW EHHFM		2	
15	583 94 72-01	ADAPTER		1	
16	542 19 89-49	O-RING		1	
17	585 97 54-01	SCREW EHHFM		1	
18	734 11 63-01	WASHER		1	
19	505 28 95-10	PUMP		1	
20	580 96 06-01	PLATE		1	
21	522 84 91-15	SOLENOID		1	12
22	580 95 84-01	BRACKET		1	
23	522 84 91-10	COIL		1	12
24	542 16 64-48	FILTER		1	
25	542 16 64-49	FILTER		1	
26	581 20 60-01	PLUG		1	
27	581 20 53-01	ADAPTER		6	
28	581 05 32-01	HYDRAULIC PUMP		1	
29	584 26 81-01	HYDRAULIC HOSE		1	
30	584 26 97-01	HYDRAULIC HOSE		1	
31	541 20 47-34	FITTING		1	12
32	522 84 91-10	COIL		1	12
33	582 22 65-01	VALVE		1	12

AD FS7000DL
LIFT BAIL

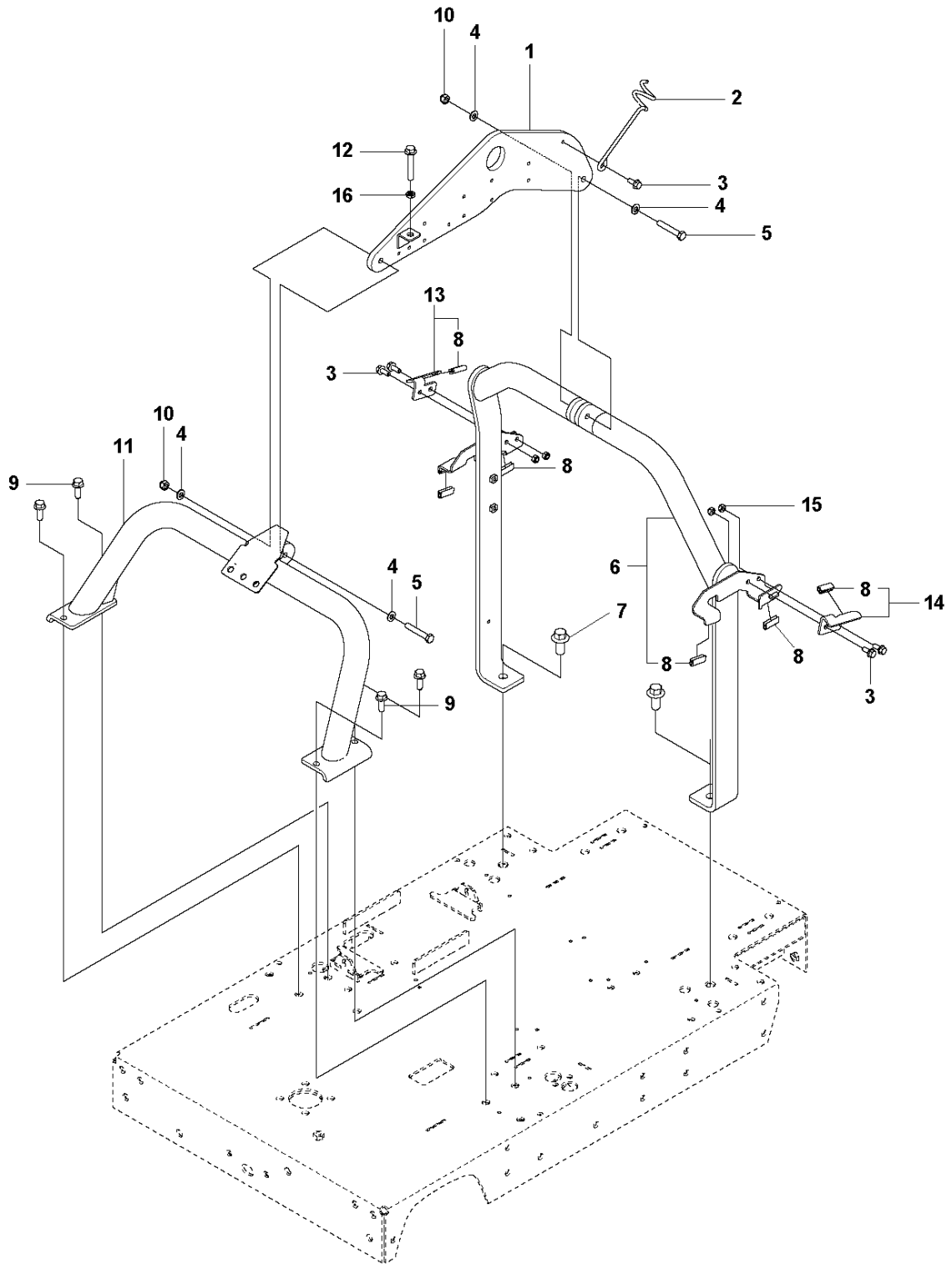

LIFT BAIL

FS7000 DL, 2017-02

Ref	Part No	Description	Remark	QTY	KIT
1	585 03 47-01	PLATE		1	
2	505 18 91-01	BRACKET		1	
3	585 97 54-01	SCREW EHHFM		5	
4	734 11 72-01	WASHER		4	
5	725 25 01-76	SCREW EHHM		1	
6	590 29 34-01	BRACKET		1	8
7	587 25 90-01	SCREW EHHFM		2	
8	586 17 58-01	PROTECTION		6	
9	585 98 04-01	SCREW EHHFM		4	
10	732 25 20-01	HEXAGON LOCKING NUT		2	
11	583 88 59-01	BRACKET		1	
12	501 85 79-01	CLAMP		2	
13	590 29 36-01	BRACKET		1	8
14	590 29 39-01	BRACKET		1	8
15	732 25 18-01	HEXAGON LOCKING NUT		4	
16	502 02 35-01	SCREW IHCSFM		2	

L FS7000DL
LIGHTNING KIT

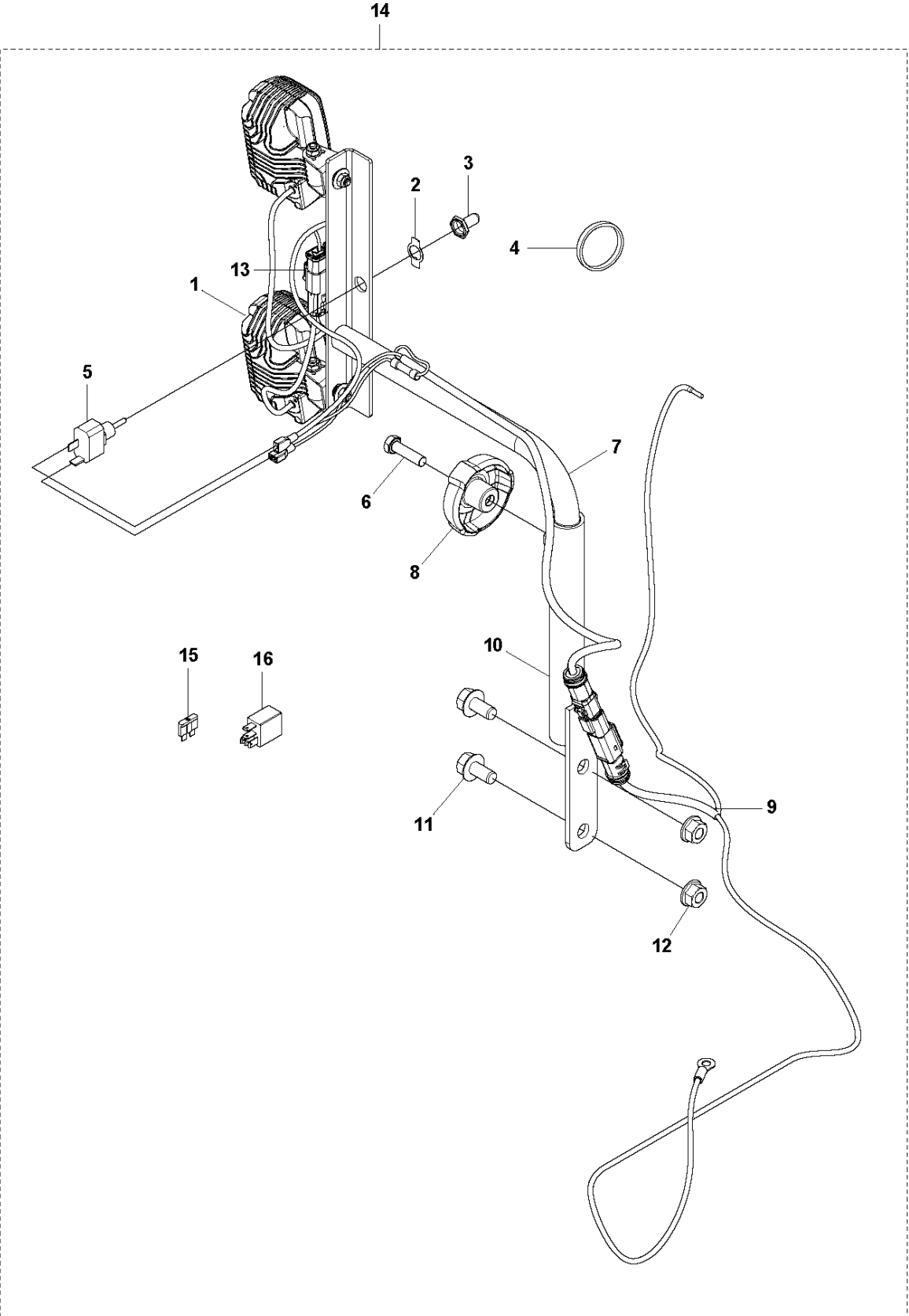

Ref	Part No	Description	Remark	QTY	KIT
1	582 77 67-01	LIGHT		2	14
2	542 09 05-52	PLATE		1	14
3	539 30 01-13	SWITCH BOOT, GREY		1	14
4	542 16 69-06	TIE WRAP		12	14
5	542 19 96-48	SWITCH		1	14
6	725 24 55-71	SCREW EHHM		1	14
7	587 35 73-01	BRACKET		1	14
8	504 56 93-01	TURNING KNOB		1	14
9	587 36 60-01	LIGHT		1	14
10	585 92 36-01	SUPPORT		1	14
11	585 97 52-01	SCREW EHHFM		2	14
12	731 71 20-51	HEXAGON NUT FLANGE		2	14
13	589 37 82-01	WIRING ASSY		1	14
14	589 65 05-01	LIGHT		1	
15	542 16 68-56	FUSE		1	14
16	581 07 45-01	RELAY		1	14

K FS7000DL
LIGHTNING KIT

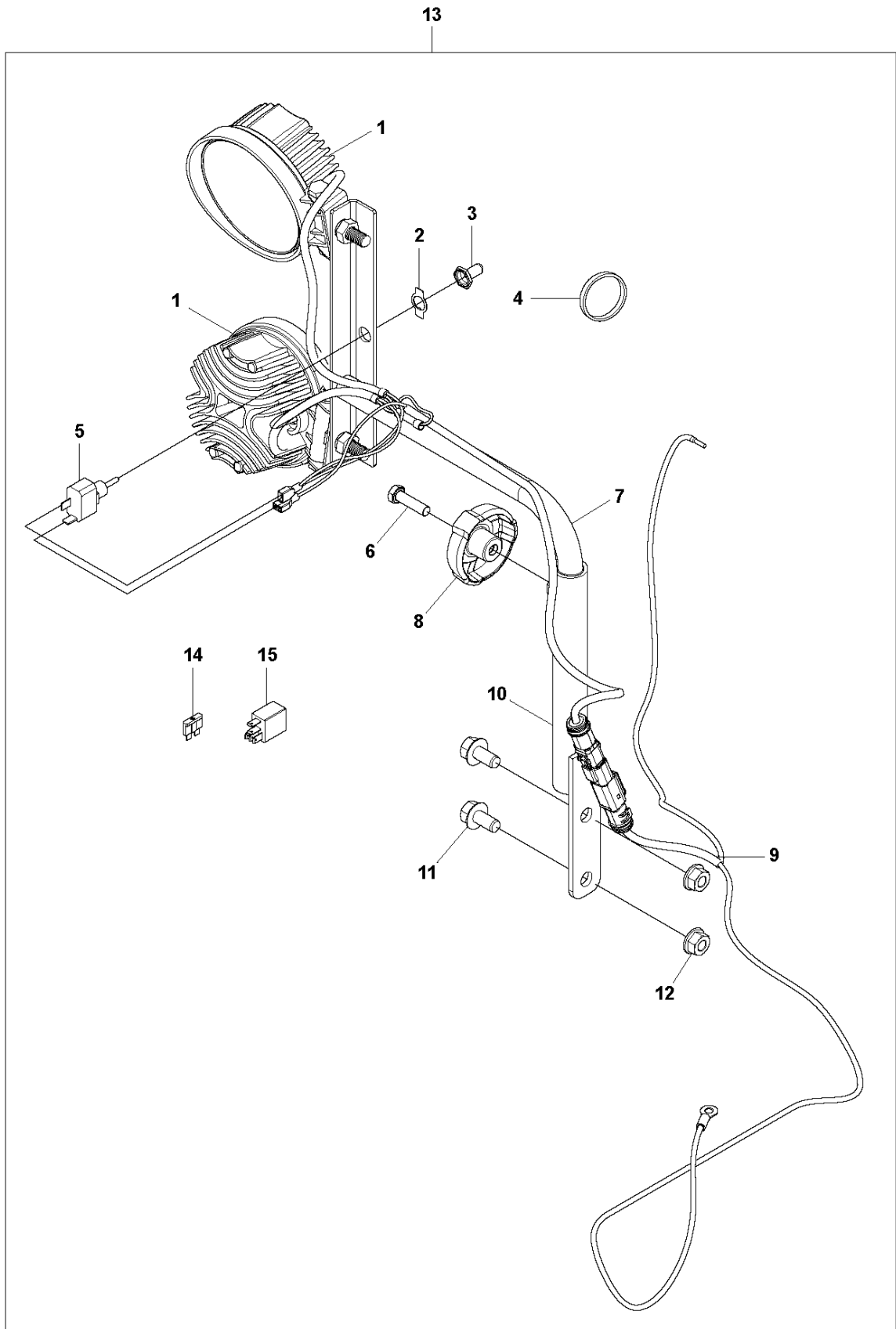

Ref	Part No	Description	Remark	QTY	KIT
1	587 33 00-01	LIGHT		2	13
2	542 09 05-52	PLATE		1	13
3	539 30 01-13	SWITCH BOOT, GREY		1	13
4	542 16 69-06	TIE WRAP		10	13
5	542 19 96-48	SWITCH		1	13
6	725 24 55-71	SCREW EHHM		1	13
7	587 35 73-01	BRACKET		1	13
8	504 56 93-01	TURNING KNOB		1	13
9	587 36 60-01	LIGHT		1	13
10	585 92 36-01	SUPPORT		1	13
11	585 97 52-01	SCREW EHHFM		2	13
12	731 71 20-51	HEXAGON NUT FLANGE		2	13
13	585 92 46-01	LIGHTING KIT		1	
14	581 07 45-01	RELAY		1	13
15	531 30 24-19	FUSE		1	13

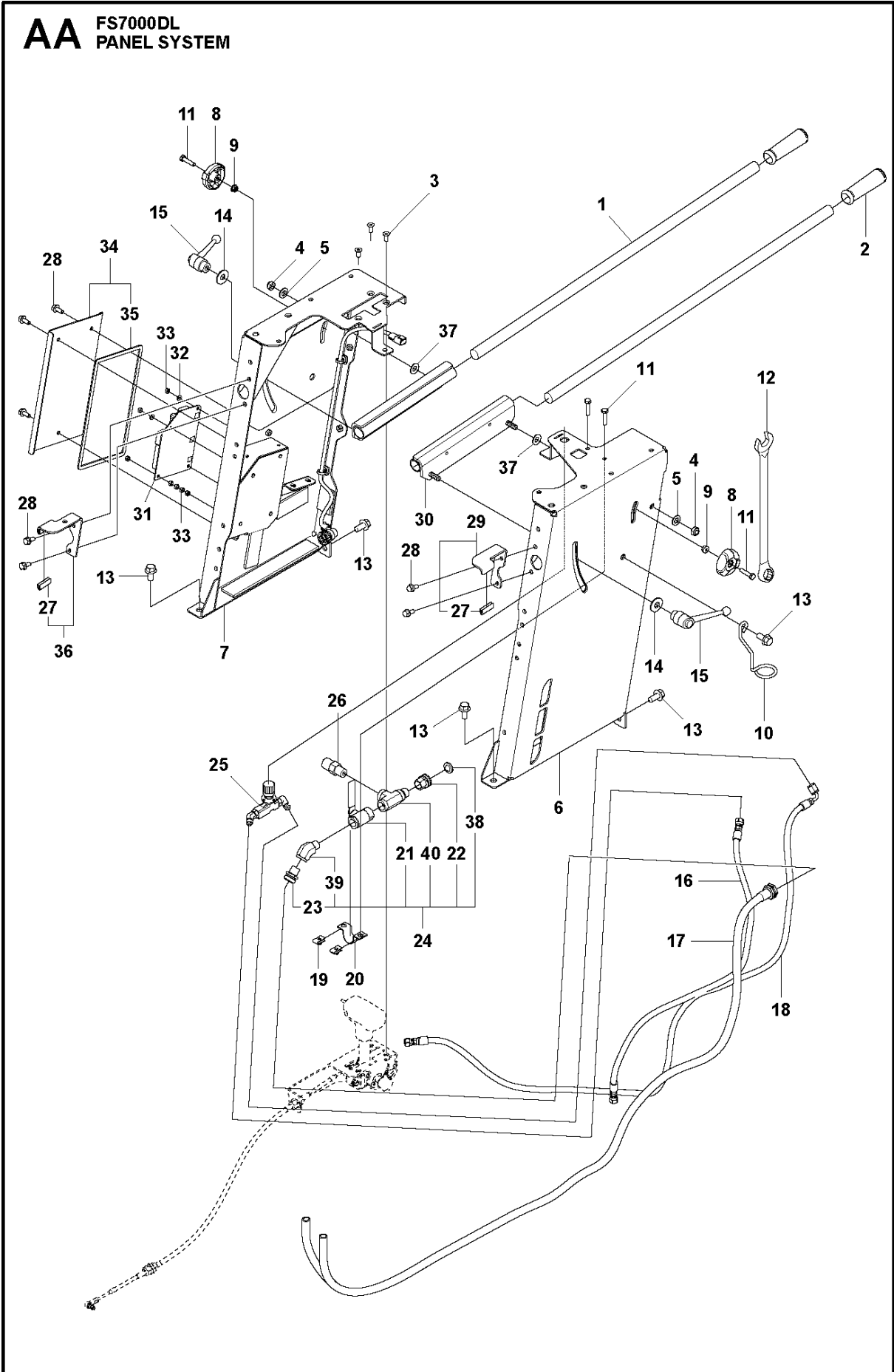

PANEL

FS7000 DL, 2017-02

Ref	Part No	Description	Remark	QTY	KIT
1	539 30 03-40	HANDLEBAR		2	
2	542 13 95-68	GRIP		2	
3	725 64 51-51	SCREW IHCSFM		3	
4	732 25 22-01	HEXAGON LOCKING NUT		2	
5	734 11 78-01	WASHER		2	
6	589 93 73-01	COWL PANEL		1	
7	589 93 72-01	COWL PANEL		1	
8	504 56 93-01	TURNING KNOB		2	
9	731 71 18-51	HEXAGON NUT FLANGE		2	
10	578 10 73-01	HOLDER		1	
11	725 24 57-71	SCREW EHHM		2	
12	504 62 64-03	WRENCH		1	
13	585 23 59-01	SCREW EHHFM		5	
14	542 02 07-45	HS350T RINGS/		2	
15	585 59 46-01	LEVER		2	
16	584 21 69-01	HYDRAULIC HOSE		1	
17	584 90 45-04	HOSE		1	
18	584 21 67-01	HYDRAULIC HOSE		1	
19	542 16 75-55	NUT		2	
20	581 19 22-01	BRACKET		1	
21	582 69 11-01	VALVE		1	24
22	539 30 02-69	HYD FIT 4045-12-8(USE 1C0013)		1	24
23	541 20 48-55	MUFFE 3/4 GH X 1/2 MPT		1	24
24	586 02 24-01	CONNECTOR		1	
25	586 41 01-01	CONTROL VALVE		1	
26	542 17 87-24	SWITCH		1	
27	586 17 58-01	PROTECTION		2	29,36
28	585 97 54-01	SCREW EHHFM		7	
29	586 61 97-01	BRACKET		1	27
30	586 92 77-01	HANDLE		2	
31	581 33 36-01	ELECTRICAL SYSTEM		1	
32	734 11 52-01	WASHER		4	
33	731 23 16-01	HEXAGON NUT		8	
34	590 19 92-01	HATCH		1	
35	579 83 39-01	SEAL		1	34
36	586 61 94-01	BRACKET		1	27
37	539 30 02-74	WASHER, FRICTION 1/2 X 1" OD		2	
38	542 04 56-40	FS900T RING/		1	24
39	542 19 91-27	VERBINDUNG 1/2 CD45-S		1	24
40	542 19 91-26	VERBINDUNG 1/2 MMO-S		1	24

F FS7000DL
POINTER

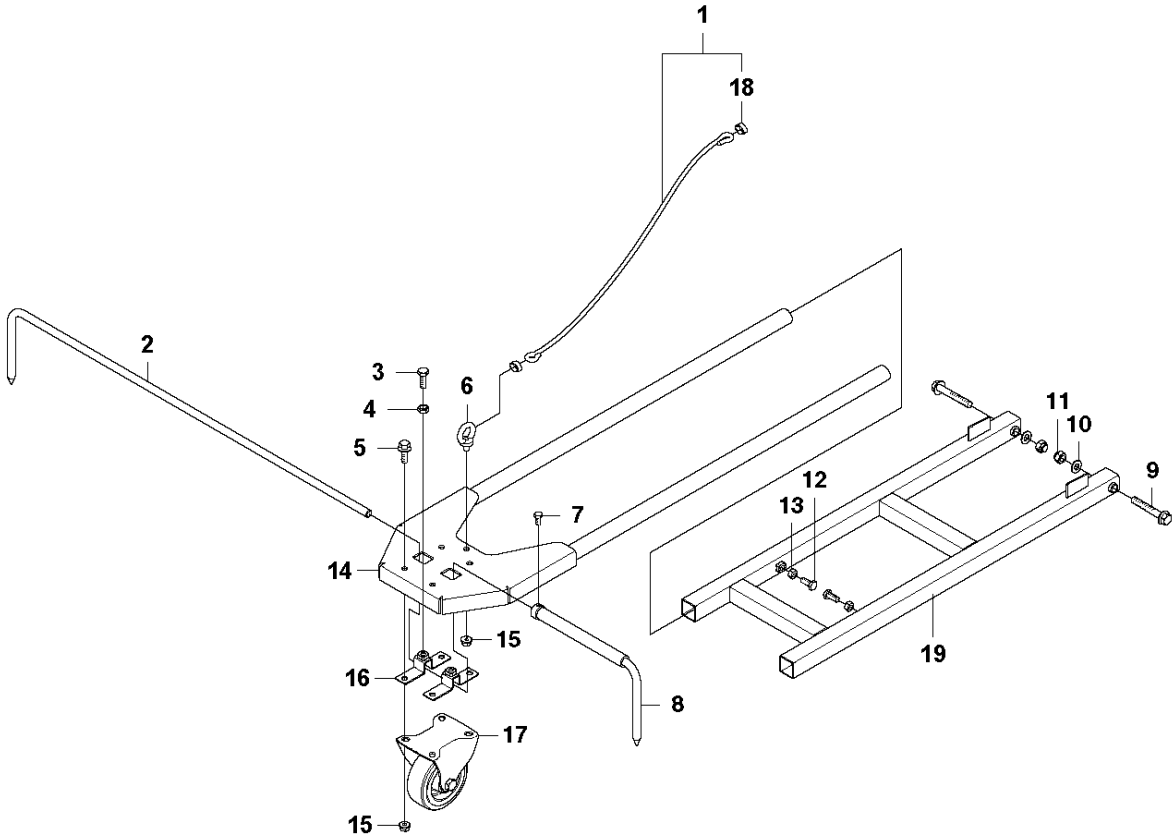

Ref	Part No	Description	Remark	QTY	KIT
1	590 29 41-01	ROPE		1	INCLUD ES 18
2	581 22 26-01	ROD		1	
3	725 24 51-71	SCREW EHHM		2	
4	731 23 18-01	HEXAGON NUT		2	
5	585 97 54-01	SCREW EHHFM		4	
6	584 91 14-01	EYE BOLT		1	
7	725 23 64-71	SCREW EHHM		1	
8	585 89 15-01	POINTER		1	
9	581 24 33-01	SCREW EHHFM		2	
10	734 11 72-01	WASHER		2	
11	732 25 20-01	HEXAGON LOCKING NUT		2	
12	725 24 51-71	SCREW EHHM		2	
13	731 23 18-01	HEXAGON NUT		2	
14	581 22 21-01	POINTER		1	
15	731 71 18-51	HEXAGON NUT FLANGE		5	
16	581 22 25-01	BRACKET		2	
17	579 85 67-01	POINTER		1	
18	541 20 04-67	CLAMP		2	1
19	581 21 37-01	POINTER		1	

AB FS7000DL
RADIATOR

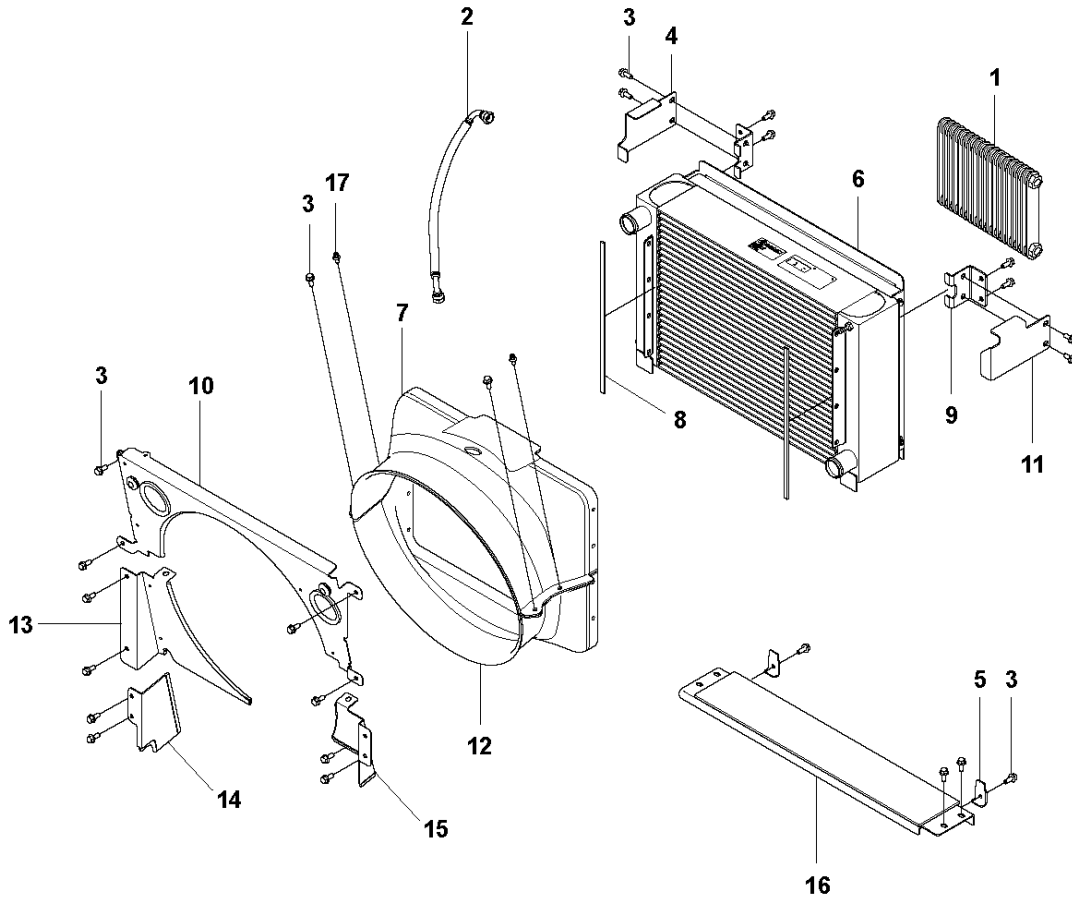

RADIATOR

FS7000 DL, 2017-02

Ref	Part No	Description	Remark	QTY KIT
1	582 18 81-01	OIL COOLER	Incl. In radiator assy	1
2	584 15 70-01	HOSE ASSY		1
3	585 97 54-01	SCREW EHHFM		26
4	586 65 77-01	PLATE	Right side	1
5	581 12 88-01	BRACKET		2
6	583 89 00-01	RADIATOR ASSY		1
7	580 87 52-01	FAN COVER	Upper	1
8	581 17 06-01	INSULATOR		2
9	583 91 21-01	BRACKET		2
10	586 07 05-01	BRACKET		1
11	586 65 76-01	PLATE	Left side	1
12	580 87 51-01	FAN COVER	Lower	1
13	586 07 08-01	BRACKET		1
14	586 07 09-01	BRACKET		1
15	586 07 06-01	BRACKET		1
16	586 34 89-01	BRACKET		1
17	542 16 66-24	BOLT		10

B FS7000DL
REAR AXLE

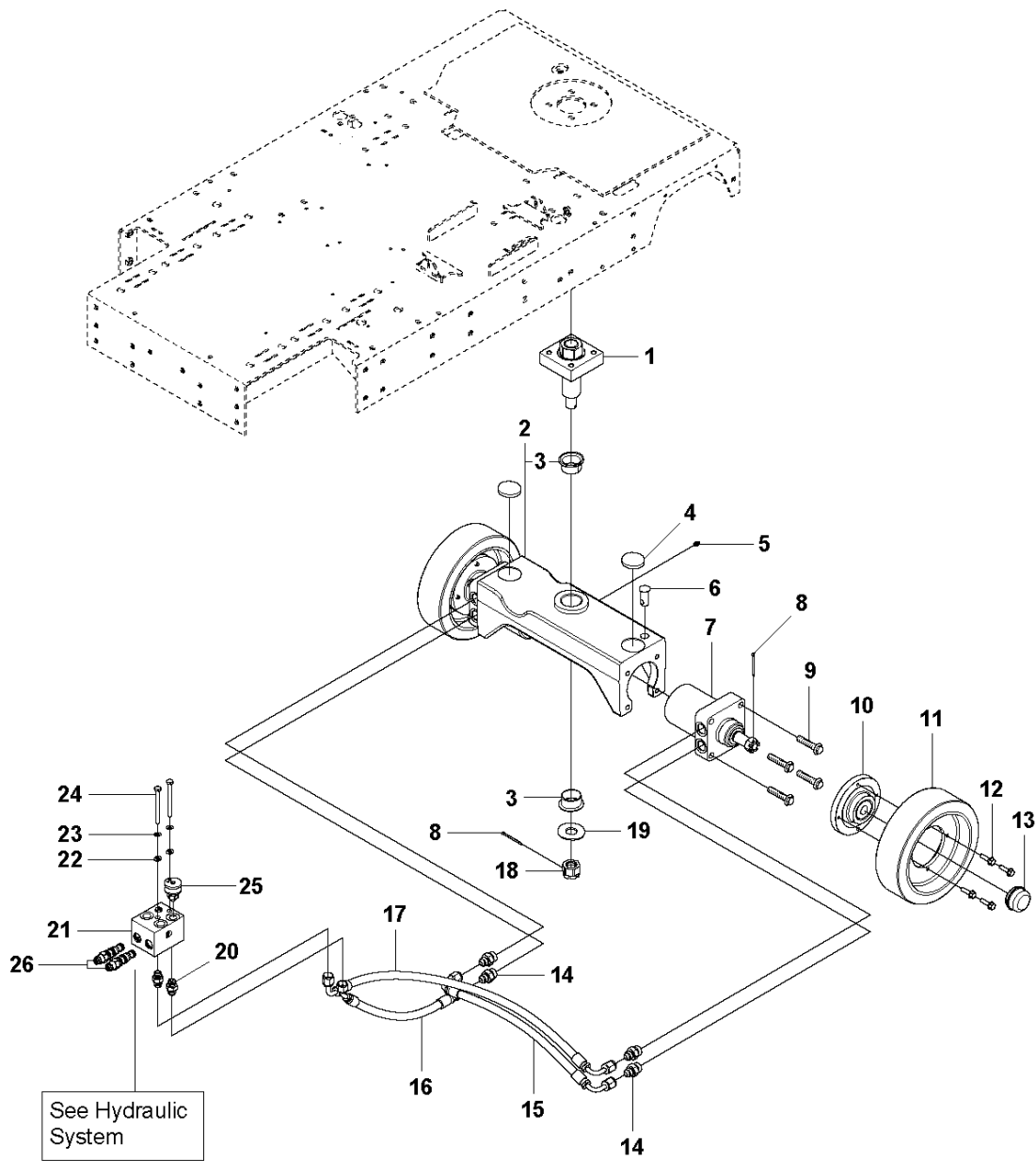

REAR AXLE

FS7000 DL, 2017-02

Ref	Part No	Description	Remark	QTY	KIT
1	587 62 35-01	KIT		1	
2	590 19 82-01	REAR AXLE	Rear axle + Bushings	1	
3	580 25 53-01	BEARING BUSH		2	
4	578 78 32-01	DISC		2	
5	504 20 45-01	GREASE		1	
6	578 78 28-01	SWIVEL		1	
7	542 19 88-78	WHEEL		2	
8	721 62 03-01	SPLIT PIN		3	
9	576 65 48-06	SCREW EHHFM		8	
10	542 19 88-43	HUB		2	
11	542 19 88-42	REAR WHEEL		2	
12	585 97 28-01	SCREW EHHFM		8	
13	539 10 25-35	CAP		2	
14	541 20 51-02	HYD.FIT.. 6400-8-10		4	
15	584 28 47-01	HYDRAULIC HOSE		1	
16	584 28 00-01	HYDRAULIC HOSE		1	
17	584 28 05-01	HYDRAULIC HOSE		1	
18	578 85 01-01	NUT		1	
19	542 16 64-80	WASHER		1	
20	583 96 82-01	ADAPTER		2	
21	581 26 77-01	VALVE		1	
22	734 11 63-01	WASHER		2	
23	735 11 64-01	SPRING WASHER		2	
24	725 24 69-51	SCREW EHHM		2	
25	542 19 89-17	KEGELVENTIL		1	21
26	542 19 94-14	CARTRIDGE		2	21

Z FS7000DL
SPEED CONTROL

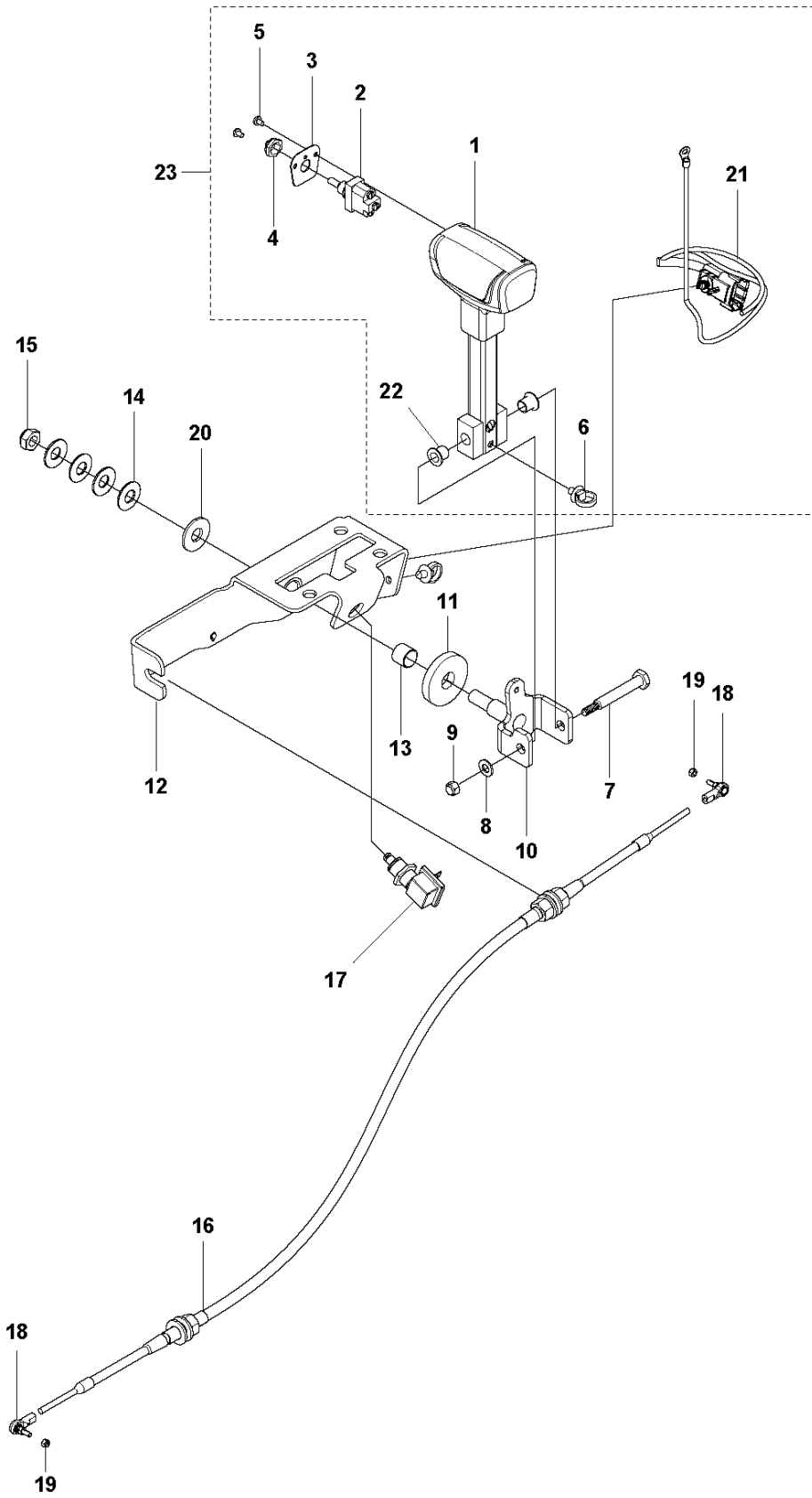

SPEED CONTROL

FS7000 DL, 2017-02

Ref	Part No	Description	Remark	QTY	KIT
1	586 94 62-01	HANDLE		1	23
2	542 18 21-02	SWITCH		1	23
3	581 11 85-01	PLATE		1	23
4	542 18 21-46	BOOT		1	23
5	724 12 85-51	SCREW		2	23
6	583 95 95-01	CLAMP		2	23
7	586 86 68-01	SCREW EHHI		1	
8	734 11 63-01	WASHER		1	
9	539 97 69-78	NUT		1	
10	579 74 50-01	ARM		1	
11	579 42 56-01	WASHER		1	
12	581 11 82-01	BRACKET		1	
13	581 06 89-01	BEARING BUSH		1	
14	542 18 31-24	SCHEIBENFEDER		4	
15	732 25 22-01	HEXAGON LOCKING NUT		1	
16	579 51 01-03	CABLE		1	
17	542 17 63-98	SWITCH		1	
18	542 16 64-66	ROD		2	
19	541 20 52-53	NUT		2	
20	542 02 07-45	HS350T RINGS/		1	
21	581 07 36-01	HARNESS ASSY		1	23
22	542 18 30-01	LAUFBUCHSE		2	23
23	587 81 20-01	HANDLE ASSY		1	

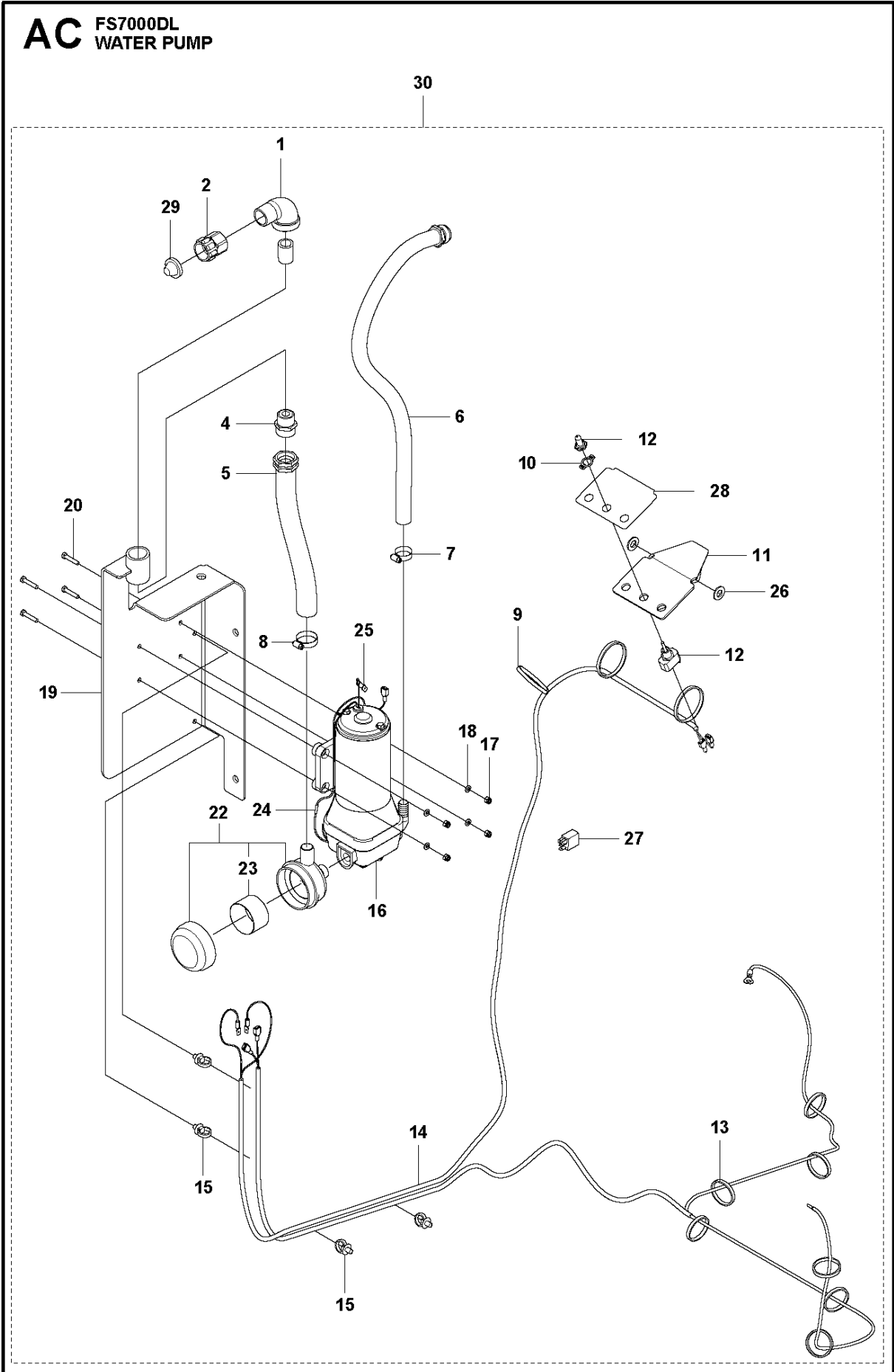

WATER PUMP

FS7000 DL, 2017-02

Ref	Part No	Description	Remark	QTY	KIT
1	541 20 45-91	ROHRVERBINDUNG 3/4"		1	30
2	541 20 46-61	VEBINDUNG 3/4 MGH X 3/4 FPT		1	30
3	542 02 02-96	FS900T TUBE FILETE/		1	30
4	542 17 86-87	ANSCHLUSSSTUTZEN 3/4 MGH X 3/4		1	30
5	542 19 96-58	HOSE		1	30
6	542 19 96-57	HOSE		1	30
7	576 31 52-05	HOSE CLAMP		1	30
8	539 30 00-11	CLAMP, HOSE, MAH-6, 5/16-7/8		1	30
9	542 19 71-01	CABLE		3	30
10	542 09 05-52	PLATE		1	30
11	590 58 12-01	BRACKET		1	30
12	589 35 51-01	CIRCUIT BREAKER		1	30
13	542 16 69-06	TIE WRAP		7	30
14	586 45 66-01	HARNESS ASSY		1	30
15	583 95 95-01	CLAMP		4	30
16	582 34 55-01	WATER PUMP		1	30
17	732 25 14-01	HEXAGON LOCKING NUT		4	30
18	734 11 46-01	WASHER		4	30
19	586 27 09-01	BRACKET		1	30
20	725 23 33-71	SCREW EHHM		4	30
22	542 19 96-41	EINLAUF FILTER		1	30
23	542 19 96-43	STRAINER SCREEN. W/P INLET FILTER		1	30
24	586 45 67-01	HARNESS ASSY		1	30
25	539 30 01-44	TERM., MALE DISCONNECT, 1/4"		1	30
26	734 11 72-01	WASHER		2	30
27	581 07 45-01	RELAY		1	30
28	582 52 10-01	DECAL		1	30
29	542 04 56-40	FS900T RING/		1	30
30	586 01 23-01	WATER PUMP KIT		1	